

Experimental determination of cervical spine mechanical properties

MAREK GZIK*, WOJCIECH WOLAŃSKI, DAGMARA TEJSZERSKA

Division of General Mechanics and Biomechanics, Department of Applied Mechanics,
Silesian University of Technology, Gliwice, Poland.

The results of research into human cervical spine mechanical parameters necessary for process modelling are presented. Our tests were divided into identification of tissues mechanical features and determination of data useful for validating human cervical spine models. Mechanical properties of the whole cervical spine as well as the stiffness of ligaments and discs were identified on the basis of tests on cadaveric spinal specimens. Thanks to our cooperation with medical practitioners, physiological cross-section areas of neck muscles were analysed using MRI. Functional computed tomography was used to determine kinematics of cervical vertebrae during head movement in sagittal and frontal planes.

Key words: human cervical spine biomechanics, spine tissues mechanical properties

1. Introduction

In last decade, modelling in biomechanics becomes more popular as a method providing information about living organisms. Reasonably assumed tissue mechanical parameters of anatomical parts have a decisive effect on model attributes. Information about physical features of biological tissues could be obtained from literature, but in many cases data describing the same element are considerably different. Personal features of specimens and lack of standards of experiments are responsible for the situation. Many research centres in the world deal with recognizing biological material parameters but the knowledge about physics of living organisms is still incomplete. Development of biomedical technique allows us to see a human organism in a wider perspective due to discovering, for example, magnetic resonance imaging (MRI), functional computed to-

mography (CT) or needle electromyography (EMG). Unfortunately, the methods have some limitations, especially because of their invasive character. The need for an experimental method to investigate the behaviour of whole cervical spine specimens under normal physiologic loads has been recognized in the literature [1], [2], [4], [11].

Several static and dynamic models of human cervical spine were built by the scientists representing the Department of Applied Mechanics, Silesian University of Technology [4], [5]. Materials parameters of such models were previously assumed only on the basis of literature data, and the situation revealed different problems. Nowadays thanks to interdisciplinary cooperation between medical practitioners and new bioengineering laboratories it is possible to carry out pioneering experiments. The results of research allowing the model material parameters to be identified and verified are presented.

* Corresponding author: Marek Gzik, Division of General Mechanics and Biomechanics, Department of Applied Mechanics, Silesian University of Technology, ul. Konarskiego 18a/18b, 44-100 Gliwice, Poland. E-mail: marek.gzik@polsl.pl

Received: April 11th, 2008

Accepted for publication: November 4th, 2008

2. Experimental determination of human cervical spine stiffness

The load–displacement response of cervical spine was determined in the case of movements in sagittal, frontal and horizontal planes. Fresh spine segments consisting of seven adjacent vertebrae (C2–Th1) and their interconnecting ligaments, soft tissue and discs were obtained from six individual cadavers (two females and four males) between the ages of 55 and 65. The specimens were examined radiographically

in order to exclude improper spines. For the load–displacement analysis spines were mounted so that the external vertebrae were rigidly attached to the grip of a testing apparatus and the middle vertebrae were free to move in response to the loads applied. The investigations were done for physiological range of motion determined on the basis of literature data [4], [7], [8], [9], [10]. The tests were carried out using static strength machine MTS Insight 10 KN (figure 1) and an adapter of a special design (figure 2).

Each segment was subjected to four tests: flexion and extension in sagittal plane, side bending in frontal plane and torsion in horizontal plane (figures 3 and figures 4).

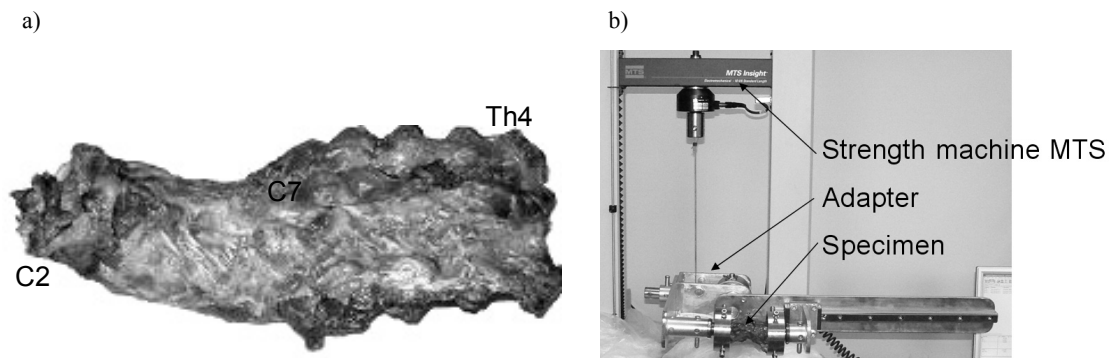

Fig. 1. Test carried out on human anatomical spine:
a) human cervical segment C2–Th4 before tests, b) experimental stand

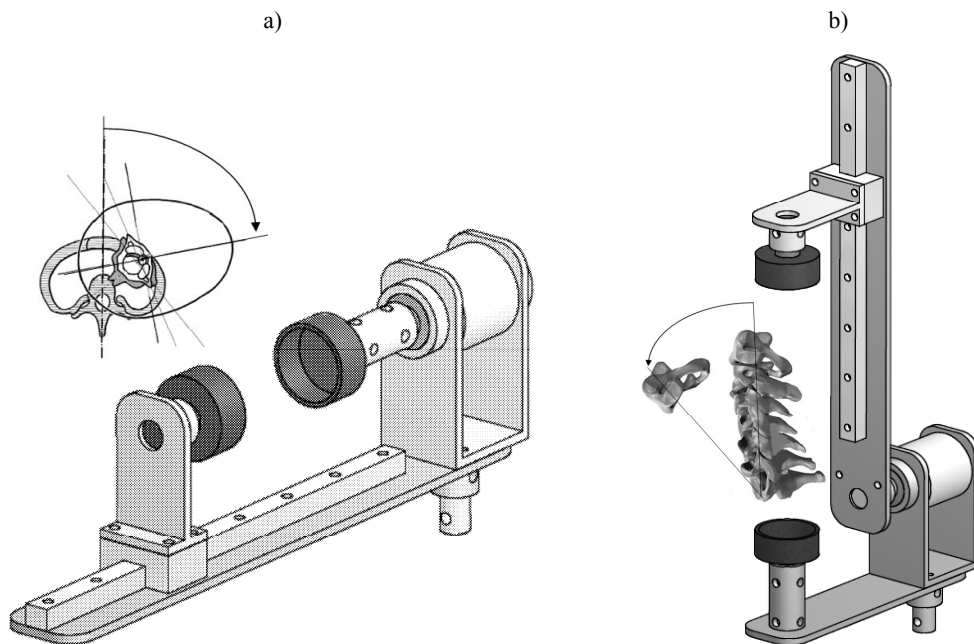

Fig. 2. Adapter adjusted to: a) flexion–extension spine movement in sagittal and frontal planes, b) rotation in horizontal plane

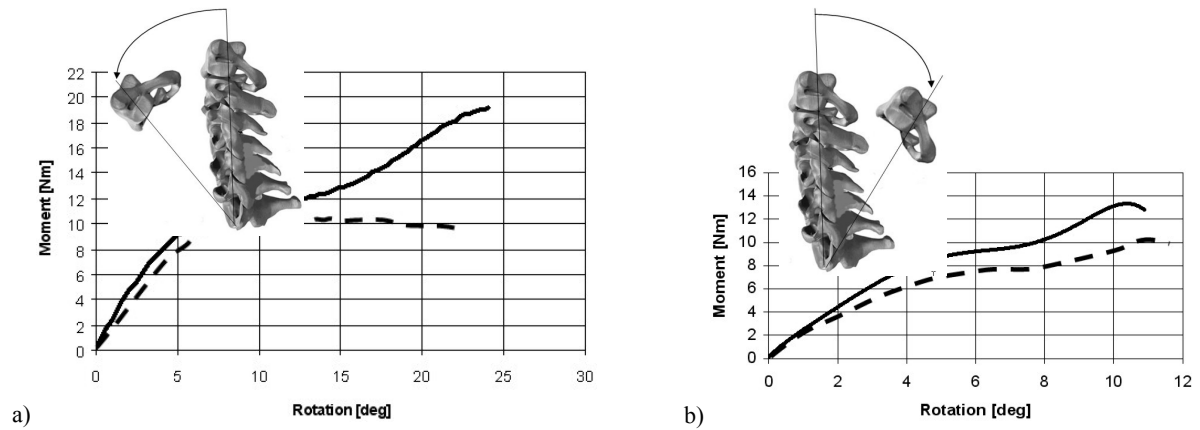

Fig. 3. Averaged load–displacement response of male (————) and female (-----) cervical spines loaded: a) flexion, b) extension

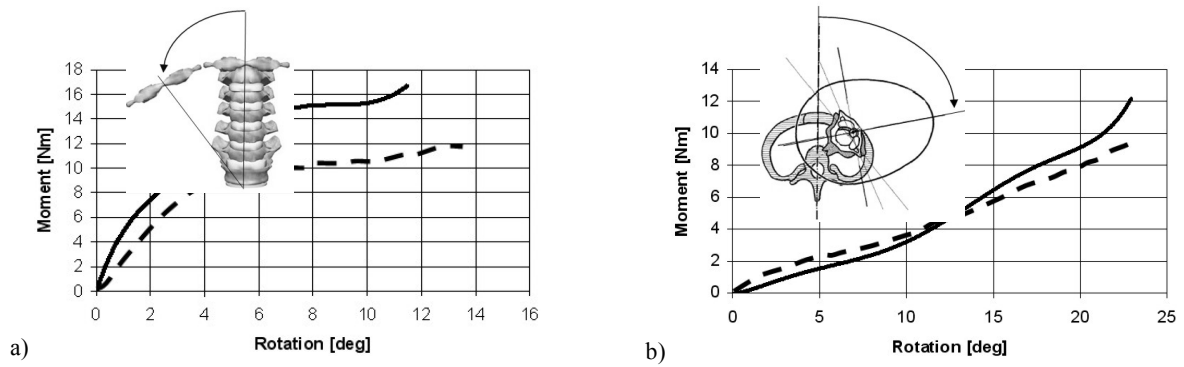

Fig. 4. Averaged load–displacement response of male (————) and female (-----) cervical spines loaded: a) side bending, b) torsion

After spine stiffness identification, six anterior longitudinal ligaments (C3–C6) and discs (C6–C7) were isolated from specimens. Average cross-section area of ligaments in C4–C5 was 38 mm².

Tensile strength of ligaments was determined. In order to avoid the problems of fixation, the ligaments were tested in situ with pressure holders (figure 5).

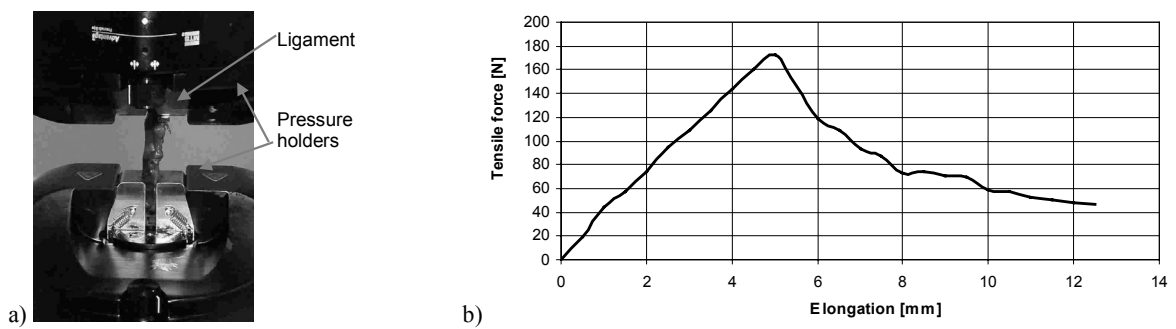

Fig. 5. Tensile test of anterior longitudinal ligament: a) photo of in situ bone–ligament–bone preparation for tensile tests, b) averaged load–elongation response

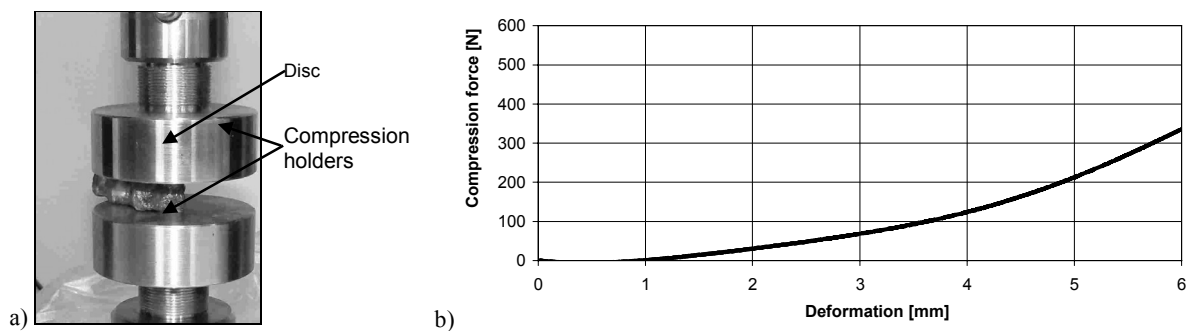

Fig. 6. Compression test of disc: a) photo of device, b) average material characteristics determined

Compressive properties of six intervertebral discs C6–C7 were determined (figure 6). Discs were isolated together with part of adjacent vertebral bodies. The total height of specimens amounted to 12 mm (6 mm front height of individual disc) and the cross-section area was 350 mm². Figures 5b and 6b present average response in male and female spines during the tests.

3. MRI of neck muscles

Nowadays there is no technique which allows individual muscle forces to be measured. Muscles role in movement could be recognized using mathematical models. The modelling of muscles is based on the information about their anatomy and physiology. Physiological cross-section area is an important parameter in the process of muscle force identification. Due to our cooperation with Voxel Diagnosis Centre in Bytom the cross-section areas of male and female neck muscles were determined (figure 7).



Fig. 7. MRI of sternocleidomastoid muscle with outline of physiological cross-section area

The experiments were conducted on five women (between the ages of 25 and 56) and five men (between the ages of 36 and 56). The group of main neck muscles responsible for head and cervical spine movement was analysed. Our research differs from those presented by other authors [3], [6], because it is based on three-dimensional analysis of muscle volume. Each muscle was framed in the space, and its cross-section area was determined. The results were obtained for natural head position. Average physiological cross-section areas for right and left muscles are presented in the table.

Table. Average physiological cross-section areas of male and female neck muscles

Muscle		Female (mm ²)	Male (mm ²)
Trapezius	R*	695	1095
	L**	731	1106
Sternocleidomastoid	R	275	364
	L	278	396
Semispinalis capitis	R	62	93
	L	64	94
Splenius capitis	R	77	94
	L	75	95
Obliquus capitis inferior	R	146	191
	L	148	185
Rectus capitis posterior major	R	74	108
	L	76	106
Scalenus medius	R	164	188
	L	158	187

* Right, ** left.

4. Human cervical spine examination using functional computed tomography

Computed tomography (CT) is the method frequently applied in the diagnosis of a human skeletal

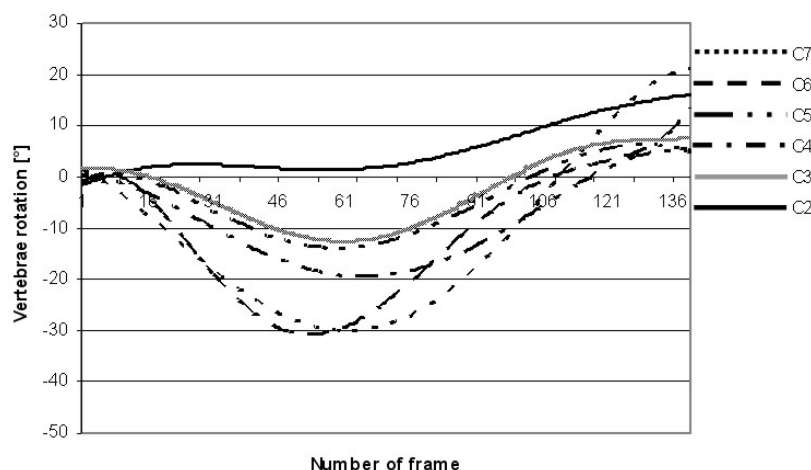

Fig. 8. Results of cervical vertebra rotation during head flexion–extension in sagittal plane

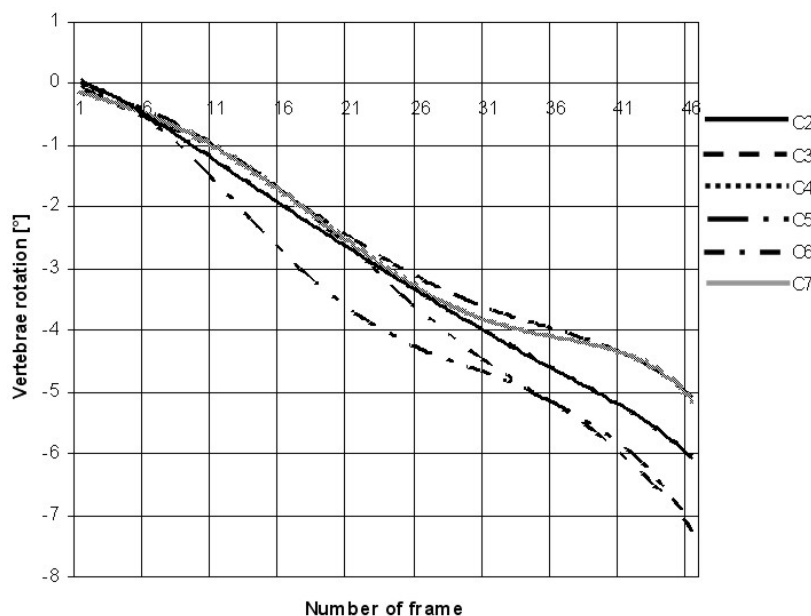

Fig. 9. Results of cervical vertebra rotation during head side movement in frontal plane

system. Nowadays various advanced techniques offer the possibility of carrying out examination during human activity. Some examples of the results of cervical vertebra kinematics analysis of head movement in sagittal and frontal planes (one adult man examined) are presented in figures 8 and 9.

In order to validate human cervical spine models, information about real object is indispensable. Typical model is verified by comparing kinematical parameters obtained from numerical simulation and from tests on human body. Rotation of cervical vertebrae presented above could be useful for models validation. Use can be made of functional computed tomography in order to validate the models of human motion organ. This validation is based on the latest achievements in medi-

cal technique. The present research should be continued which allows average kinematical parameters to be determined for male and female spines on the basis of a representative sample of people.

5. Conclusions

Such parameters as stiffness or elastic modulus, physiological cross-section area of muscles and vertebra kinematical parameters are required for a mathematical modelling.

The analysis of male and female cervical spine stiffness revealed a similar spine response to torsion in

horizontal plane, the others characteristics showed that male spine is stiffer and transmits greater loads. The anatomical construction of human cervical spine restricts in a special way the movement in frontal plane. The side bending of head activates most effectively neck muscles.

Six anterior longitudinal ligaments and discs were tested during the experiments. The ligaments are especially active during strip elongation, while the discs – during tension and compression. A biomechanical model design is connected with some simplified assumptions. The characteristic of ligaments proves that linearization of the function describing their response is appropriate for a physiological range of the elongation (up to 6 mm). The same statement made to the disc does not correspond with the facts. The disc response to tension and compression should be treated as nonlinear.

Due to advanced biomedical technique we have faced some new possibilities of determining physical tissue parameters. Up to now physiological cross-section areas of muscles were determined on the basis of MRI scanning in one intersection plane. Thanks to 3D Fiesta module of MRI it is possible to frame each muscle in the space and then to measure its geometrical parameters. The method of physiological cross-section areas allowed the main neck muscles to be determined in five women and five men. The results prove that in many cases the same muscles have not the same geometrical parameters. This means that the assumption about symmetrical to middle sagittal plane neck response is false. The differences were observed especially in elderly people, which is connected with the degeneration of facet joints and discs.

Validation is an important part of model building. In the paper, new techniques of measuring some kinematical parameters during physiological activity were presented and proposed as a way of validating the model of human organ motion. Comparison of the results from numerical simulation and tests on real object makes the success in biomechanical modelling more spectacular. The new methodology of experi-

ments can contribute to the creation of much more realistic models which prevent neck injuries or improve surgical treatment technique.

Acknowledgements

The research was supported by the Polish Ministry of Science and High Education, project no. 4 T07B 01730.

References

- [1] BĘDZIŃSKI R., *Biomechanika inżynierska – zagadnienia wybrane*, Oficyna Wydawnicza Politechniki Wrocławskiej, Wrocław, 1997.
- [2] BOCHENEK A., REICHER M., *Anatomia człowieka I*, Wydawnictwo Lekarskie, PZWL, Warszawa, 1990.
- [3] CONLEY M.S., MEYER R.A., BLOOMBERG J.J., FEEBACK D.L., DUDLEY A.A., *Noninvasive analysis of human neck muscle function*, Spine, 1995, Vol. 20, No. 23, 2505–2512.
- [4] GZIK M., *Biomechanika kręgosłupa człowieka*, Wydawnictwo Politechniki Śląskiej, Gliwice, 2007.
- [5] GZIK M., *Modelling of human spine and biomechanical analysis of correlations between human body movement and internal forces*, Material of International Conference RRS 2007, Road Safety and Simulation, Rome, 2007.
- [6] KAMIBAYASHI L.K., RICHMOND F.J.R., *Morphometry of human neck muscles*, Spine, 1998, Vol. 23, No. 12, 1314–1323.
- [7] MYERS B.S., MCELHANEY J.H., NIGHTINGALE R., *Cervical spine injury mechanisms, P-276, Head and Neck Injury*, Society of Automotive Engineers, Warrendale, 1994.
- [8] PANJABI M.M., CHOLEWICKI J., NIBU K., GRAUER J., BABAT L.B., DVORAK J., *Critical load of the human cervical spine: an in vitro experimental study*, Clinical Biomechanics, 1998, Vol. 13, No. 1, 11–17.
- [9] PANJABI M.M., CRISCO J.J., VASAVADA A., ODA T., CHOLEWICKI J., NIBU K., SHIN E., *Mechanical properties of the human cervical spine as shown by three dimensional load–displacement curves*, Spine, 2001, Vol. 26, No. 24, 2692–2700.
- [10] PANJABI M.M., MYERS B.S., *Cervical spine protection*. Report, prepared for NOCSAE, 1995.
- [11] SEIREG A., *Biomechanical analysis of the musculoskeletal structure for medicine and sports*, Hemisphere Publishing Corporation, New York, 1989.