

The real rotational capacity of the human joints - the muscular and gravitational torques and the foot as a platform

Jacek Dygut¹, Monika Piwowar^{2*}

¹ Medicare Clinic, 603 Oxford Road, Reading RG30 1HL

² Jagiellonian University Medical College, Faculty of Medicine, Department of Bioinformatics and Telemedicine, Kraków, Poland

*Corresponding author: Monika Piwowar, Jagiellonian University Medical College, Faculty of Medicine, Department of Bioinformatics and Telemedicine, Kraków, Poland, e-mail address: monika.piwowar@uj.edu.pl

Submitted: 6th June 2024

Accepted: 3rd October 2024

Abstract

Purpose: The purpose was to answer: What is the relationship between torques acting on the human body? How does the triceps calf muscle balance the weight of a tilted body? What is the foot's role in the tilting body?

Methods Two research models were developed. Model 1 - The one-sided lever system consists of a flat bar with, an axis of rotation, used to determine the weight and torque at a given point on it. Model 2 - The two-sided lever system consists of a flat bar imitating a tilted body counteracted by the Achilles tendon, and a platform imitating a foot. The centre of gravity was determined without considering "the foot"

Results When the centre of gravity of the human body tilts, the foot does not participate in the tilt of the rest of the body, because it tilts on the axis of rotation of the upper ankle joint, and not on the plantar side of the foot. The further the point of gravity is from the axis of rotation, the smaller the weight, but the moments of gravity are the same. The apparent weight loss when lifting it with one-sided support (getting up from a squatting position) is a real decrease in the gravitational moment and the lifting moment counteracting it.

Conclusions In analysing human biomechanics, focusing on real rotational force (not only the forces of muscle and gravity) is necessary (Muscle moments balancing gravitational moments). The research may help develop effective rehabilitation methods, surgical procedures, and sports training.

Keywords

gravitational torques, muscle moments, foot as a platform, joint rotational capacity

1. Introduction

In the literature, there are many ambiguities in the descriptions of the action of human muscle forces, which has consequences for the description of pathological conditions and the design of therapy [17, 9, 1]. Medical papers describing foot are dominated by the concept of force instead of torques. The arms of the forces in rotational movements of joints are neglected. Their values translate into a multiplication of the value of rotational force. Under the conditions of the Earth's gravitational field, in the body of an upright human, there is a constant "fight" between the gravitational moments of individual body segments and the muscular moments that balance them [6].

The starting point for understanding the "play of torques" in the human body is to define the body's Center of Gravity (CoG). This determines the correct determination of the force of gravity relative to the axis of rotation of a given joint, and therefore also the moment of gravity, which is balanced by muscle moments. For considerations regarding the human body, the gravitational field is assumed to be uniform, so the centre of gravity and the centre of mass is at the same point. Because the human body can assume various positions, the CoG can change its position and even be located outside the body, e.g. when a person reaches feet by hand [11]. After a series of population measurements, it was assumed that the CoG in an upright position is located at an average height of ~ 57% of a man's height and ~ 55% of a woman's [4, 5, 8, 16]. The position of CoG changes with body structure, posture, age, and gender [19, 14]. Infants have the highest placed overall centre of gravity, children have it lower, and adults have the lowest. A gymnast with a well-developed shoulder girdle and upper limbs may have a higher-located CoG than a soccer player with well-muscled legs [12].

Abnormal positioning of the CoG causes many postural abnormalities and related clinical consequences [8]. Non-physiological CoG shift has been shown to influence several pathologies. For example, patients with chronic low back pain tend to place their centre of gravity excessively towards the back [10].

In medicine and life sciences up to date, it is stated that when the body tilts (with fully supported feet), the entire weight is concentrated in the CoG tilts as mentioned above. In the paper was shown that this is not true. It was indicated, i.e. that the foot does not participate in the body tilting, and the CoG of the tilting body has a different location (it is located higher) than previously assumed. This seemingly not great weight of the feet, i.e. a difference of about 2.6 kg, which must be subtracted from the total weight of the human body, has a diametrical effect on gravitational torques, and therefore on the strength of the triceps calf muscle and muscle moment and joint pressure force. All this has an impact on the approach to the analysis of muscle and joint loads for medicine or designing sports training. The paper focused on the description of the tilting of the centre of gravity (CoG) as a reference point, as well as the tilting of points located above and below the CoG without taking into account the support platform ("the feet"). The importance of the body's gravity at these points and the torque of gravity and balancing it with the muscle torques were demonstrated with the model. It has been proven that the increase in perceived body weight or its decrease when tilting the body or e.g. lifting it from a squatting position is not related, as is commonly believed, to the action of gravity force and muscle forces on the deep sensory receptors [15, 3]. It is the effect of the product of the force

value and the force arm, i.e. the moment of force (torque). This distinction has important clinical and diagnostic consequences and may significantly change the approach to designed diagnostic methods, as well as conservative and surgical therapies.

2. Objectives

The aim of the research was to :

- check what is the relationship between torques acting on the human body and what role they play in maintaining a vertical posture,
- show how the triceps calf muscle balances the weight of a tilted body,
- show the function of the foot in the tilting human body.

3. Materials and methods

3.1 Design and purpose of the research

The research aimed to describe the relationships of forces, arms of the forces, and torques in the model systems, and then relate the obtained observations to the human body. The research was based on two research models.

1. Research based on model 1 - one-sided lever system

- Assessment of the weight in selected points on the object depending on its inclination angles.
- Assessment of the weight values, an arm of the force, and torques at various points on the object with a constant tilting angle.

2. Research based on model 2 - double-sided lever system

- Testing the balancing of the gravitational moment at a constant "body" weight with the "muscular" (imitation of the triceps calf muscle) moment with a constant value of the arm of the force.

3.2 Method for calculating the arm of gravity and torque

The arm of gravity (r) was determined using the formula for the cosine of the flat bar angle (α) to the ground according to formula (1) (Fig. 1C).

$$r = \cos(\alpha) * k \quad (1)$$

where

k - distance from the axis of rotation to the gravity force measurement point,

α - angle of inclination of the flat bar relative to the ground

The torque (M), i.e. the product of the force value (F) and the arm of the force (r), was calculated from formula (2).

$$M = F * r \quad (2)$$

where:

r (arm of force) – the smallest distance of the line of force action from the axis of rotation, perpendicular to the line of force action and the axis of rotation,

F – muscle force.

3.3 Method of determining the centre of gravity (CoG) using the one-sided lever method

Having the resultant of the force F_1 [kG] and the length of the lever arm l [cm], the direct position of the CoG was calculated based on the equations of gravity moments (Fig. 1A).

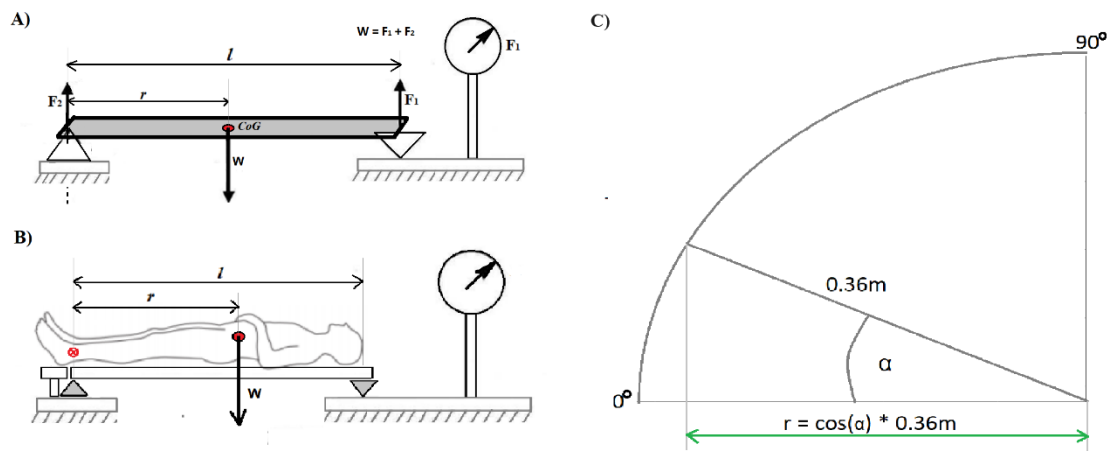

Figure 1. Determining the centre of gravity of the CoG using the one-sided lever method. A) A metal flat bar (grey) placed in a horizontal position enabling measurement of the reaction force. r – arm of the force, l – length of the lever, W – weight of the flat bar, F_1 – reaction force at the fulcrum on the scale, F_2 – reaction force at the rotation point (support point of the one-sided lever). B) Determining the centre of gravity for a human body tilting on the trochlea of the talus. The fulcrum for the one-sided lever is located on the axis of the upper ankle joint (red circle with a cross). The weight of the foot is not included in the body weight because it provides a support platform for the tilting body. C) Method of calculating the force arm (r) with a known angle of inclination and distance from the axis of rotation to the center flat bar gravity (CoG).

Since the moments of gravity W and reaction F_1 are balanced, and the moment of force F_2 is equal to 0 (the arm of force F_2 is also equal to 0) (3), then:

$$W * r = F_1 * l \quad (3)$$

$$M_W = M_{F_1} \quad M_W - M_{F_1} = 0$$

where:

W – gravity force,

F_1 – reaction force at the fulcrum on the scale,

r – force arm W ,

l – lever length (force arm F_1),

M_W - moment of gravity,

M_{F_1} - the moment of the reaction force of the fulcrum on the scale.

From the formula for the balance of moment of force (3), the arm of the gravitational force r (4) was determined, i.e. the distance between the fulcrum of the one-sided lever and the projection of the centre of gravity.

$$r = \frac{F_1 * l}{W} \quad (4)$$

where:

r – arm of the force

l – lever length (arm of the force F_1)

W – weight of the body

F_1 – reaction force

In the case of determining the centre of gravity, which is tilted in the upper ankle joint of the human body, the weight of the feet is not included in the CoG calculations. To eliminate the weight of the feet, the feet are supported to eliminate the torque on the other side of the axis of the upper ankle joint generated by the centre of gravity of the feet (Fig. 1B).

3.4 Description of Research Models

Model 1

A model was made of a metal bar weighing 1.275 kg, 0.74 m long, 0.0455 m wide, and 0.0055 m thick (Fig. 2A). A pivot hinge is mounted at one end of the bar. The CoG of the flat bar was determined, which was located at a distance of 0.37 m from the rotation axis (the fulcrum of the one-sided lever). Points were also marked on the flat bar at every 0.0925 m from the CoG

in the distal (1d, 2d, 3d, 4d) and proximal (1p, 2p, 3p) directions . Dynamometers (Ruhhy® 0.005kg - 40kg) were used to test the force of gravity at individual points.

Model 2

By simplifying the complexity of the human body structure, which consists of many segments with many centres of gravity, it was reduced to a single flat bar with one centre of gravity (CoG) determined by the unilateral lever method.

The model consisted of (Fig. 2B):

- a metal flat bar with a load imitating the head with a total weight of 2,725 kg, a length of 1.82 m with the CoG centre of gravity at a height of 55%, i.e. 1,001 m from the rotary hinge imitating the axis of the upper ankle joint, and the point of gravity imitating the place of the insert of the Achilles tendon (TRI point of gravity),
- a string indicating the line of action of gravity (vertical),
- a wooden platform imitating a human foot,
- a hinge imitating the upper ankle joint connecting the flat bar with the platform,
- dynamometer steel cable imitating the action of the triceps surae muscle (F_{TRI}). One end of the cable was attached to the flat bar at the TRI point of gravity, i.e. halfway between the centre of gravity of the flat bar and the axis of rotation, and the other end was attached to the platform (on calcaneal tuberosity in the foot). The steel cable was attached in such a way that the shortest distance from it to the hinge rotation axis was 0.04 m (which is the arm of the force of the triceps surae muscle).

In determining the CoG, the element imitating the foot was not taken into account, because it does not participate in the body's tilt (it is, as it were, an element of the ground).

The model simulated the main muscle that balances the tilting of the human body in the sagittal plane, which is the triceps surae (TRI). It is a muscle whose line of action crosses the axis of the upper ankle joint from behind.



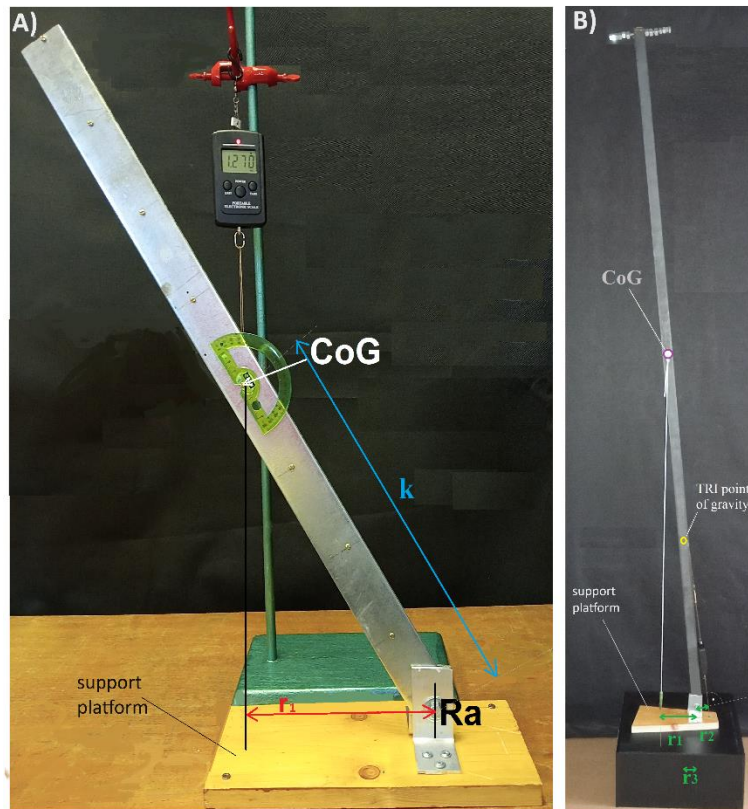

Figure 2. Research models. A) Model 1 - one-sided lever system consists of a flat bar with, an axis of rotation, used to determine the weight and torque at a given point on it. B) Model 2 - two-sided lever system consists of a flat bar imitating a tilted body counteracted by the Achilles tendon, and a platform imitating foot. CoG – the centre of gravity without a support platform, TRI point of gravity - imitation of the proximal insert point of the triceps calf muscle, Ra – imitation of the axis of rotation of upper ankle joint, k – the distance between Ra and GoC, r_1 – an arm of gravity force, r_2 – an arm of muscle force, r_3 – an arm of gravity in TRI point of gravity. Support platform imitates foot.

3.5 Programs/Statistics

The *ggpubr* and *ggplot2* libraries of R (R Core Team, 2019) and CoreIDRAW were used to present the measurement data.

4. Results

4.1 The force of gravity and torque depending on the angle of the tilting of the centre of gravity.

A measurement experiment was performed using model 1. A metal flat bar was tilted at various angles. In the calculations, only the flat bar's centre of gravity (CoG) was referred to (Fig. 3ABCD).

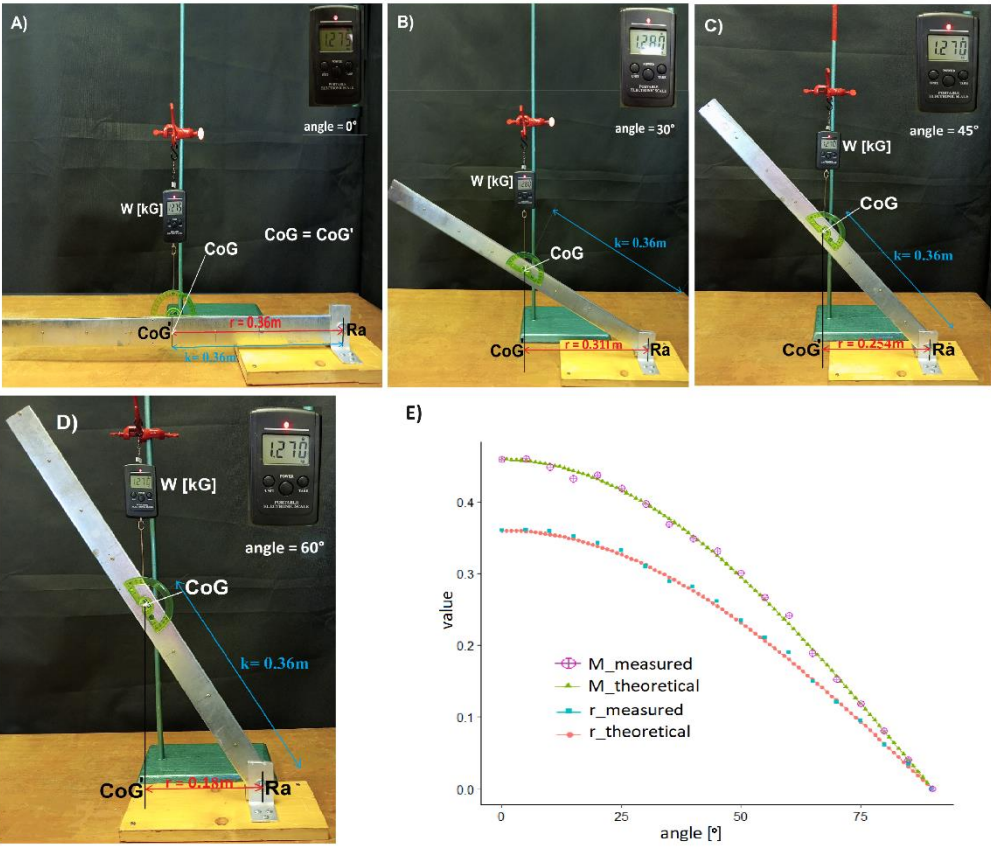

Figure 3. The result of measurements of the force of gravity (W) and the force arm (r) at different angles of inclination of a metal flat bar. A) horizontal positioning of the flat bar, the maximum value of the arm of gravity $r=0.36\text{m}$, gravity force $W=1.275\text{kG}$, B) at an angle of 30° to the ground, $r=0.31\text{m}$, $W=1.280\text{kG}$, C) at an angle of 45° to the ground, $r=0.261\text{m}$, $W=1.270\text{kG}$, D) at an angle of 60° from the ground, $r=0.19\text{m}$, $W=1.270\text{kG}$, E) Dependence of the torque values and the force arm on the flat bar inclination angle from 0° to 90° .

Based on formulas (1) and (2), knowing the distance (k) between the axis of rotation (Ra) and the centre of gravity of the flat bar (CoG), the lengths of the arms of gravity at specific angles of inclination of the flat bar and the moments of gravity were calculated (Table 1).

Table 1. Values of the gravity arm (r), gravity force (W), and torques (M) at different flat bar inclination angles (α). k - distance from the axis of rotation to the gravity force measurement point.

$^\circ$	$\cos(\alpha)$	r [m]	W [kG]	M [kGm]
----------	----------------	---------	----------	-----------

0	1	0.36	1.275	0.459
30	0.866	0.311	1.28	0.398
45	0.707	0.254	1.27	0.323
60	0.5	0.18	1.27	0.228
75	0.259	0.093	1.274	0.118
90	0	0	1.275	0

The experiment showed that:

- The value of the force of gravity measured at the centre of gravity of the flat bar is equal to the weight of the entire flat bar, i.e. $W = 1.275\text{kG}$, and does not change with the angle of inclination of the flat bar (Fig. 3A-D). Slight differences in measurements are due to measurement errors.
- In the vertical position of the flat bar (90° angle), the value of the arm of gravity r is zero, so the moment of gravity is also zero. Each deflection of the bar generates a torque, the value of which depends on the deflection angle and is greater the greater the deflection of the flat bar from the vertical (Fig. 3E).

4.2 Gravity forces and torques at points on the flat bar.

Measurements were made using model 1. Gravity forces were measured at various distances from the rotation axis with the flat bar positioned at a constant angle $\alpha = 27^\circ$ (Fig. 4ABC, Table 2).

Table 2. Measurements of barbell weight (W) and moment arms of gravity (r) at different distances from the axis of rotation (from proximal "p" to distal "d"). CoG – barbell centre of gravity, r – moment arm of gravity, k – barbell length (flat bar) measured from the axis of rotation to a specific point (3p, 2p etc.), s - distance from GoC in the distal and proximal direction, M – the moment of gravity.

distal/ proximal	k [m]	s [m]	W1 [kG]	W2 [kG]	W3 [kG]	W [kG] mean	% of total W	r [m]	M [kGm]
4d	0.74	0.37	0.635	0.635	0.615	0.63	49.28	0.659	0.414
3d	0.647	0.277	0.72	0.72	0.72	0.72	56.47	0.576	0.415
2d	0.555	0.185	0.845	0.84	0.84	0.84	66.01	0.494	0.416
1d	0.462	0.092	1	1	1	1	78.43	0.412	0.412
CoG	0.37	0	1.275	1.265	1.275	1.27	99.74	0.329	0.419
1p	0.277	0.092	1.7	1.7	1.705	1.7	133.46	0.247	0.42
2p	0.185	0.185	2.58	2.59	2.54	2.57	201.57	0.164	0.423
3p	0.092	0.37	5.105	5.18	5.2	5.16	404.87	0.082	0.425

The arms and moments of gravity at individual points were calculated according to formula (1) (2). Examples of force arms and torques for selected points on the flat bar were as follows $r_{p1} = 0.247\text{m}$, $r_{CoG} = 0.33\text{m}$, $r_{d4} = 0.66\text{m}$, $M_{p1} = 0.419\text{kGm}$, $M_{CoG} = 0.417\text{kGm}$, $M_{d4} = 0.419\text{kGm}$ (Fig. 4ABC).

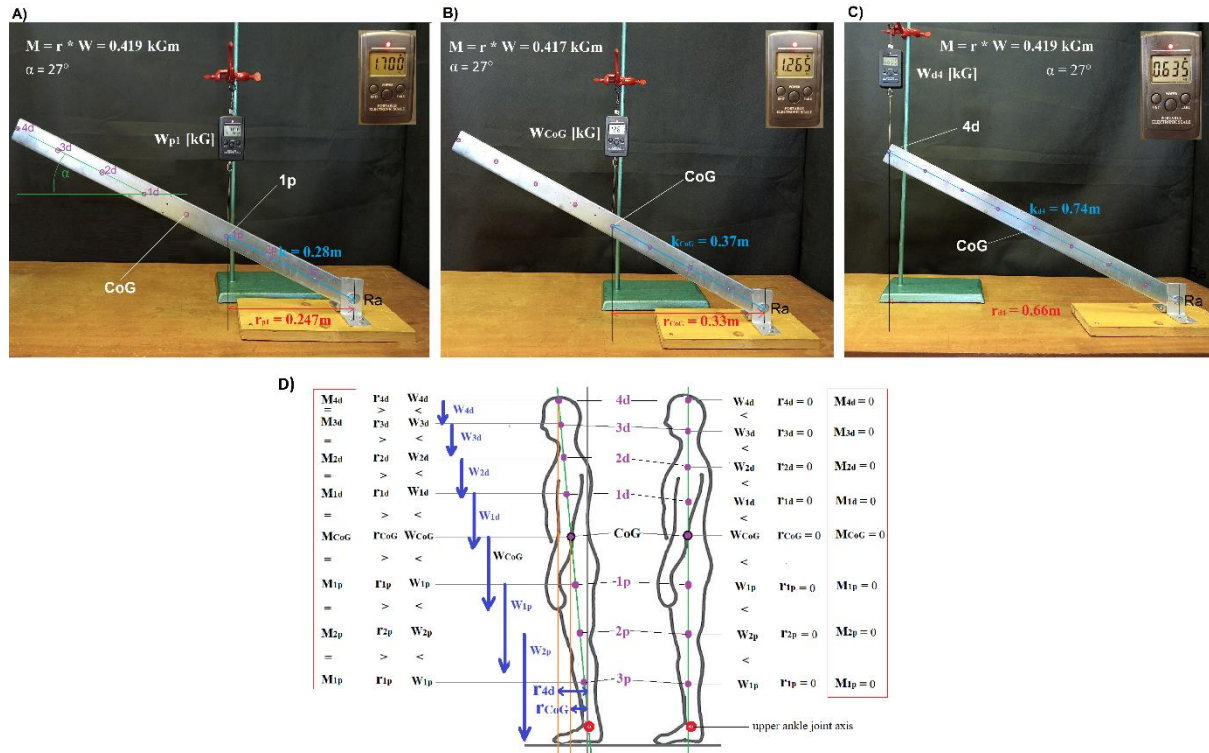

Figure 4. The result of measurements of gravity forces (W) and arms of forces (r) at a constant value of the flat bar angle $\alpha = 27^\circ$. A) measurement of gravity at a distance of $1p$ (0.092m from the centre of gravity of the flat bar towards the axis of rotation), B) measurement of gravity at the centre of gravity of the flat bar (CoG), C) measurement of gravity at a distance of $4d$ ($0.092\text{m} \cdot 4 = 0.37\text{m}$) from the centre of gravity of the flat bar in the distal direction. D) The distribution of torques concerning the upper ankle joint at individual points of the human body in a tilted and upright position.

Having the value of the force arms and gravity forces at each designated point on the flat bar, the moments of gravity forces were calculated for each of them based on formulas (1) (2) (Table 2). The experiment showed that:

- The moments of gravity for all points on the flat bar at a specific angle of inclination have the same value, which oscillated around the value of 0.419 kGm . As we move away from the axis of rotation, the value of the force of gravity decreases, while the arm of the force of gravity increases accordingly (Table 1).

- Regardless of the angle of the flat bar, the weight at a given point on the flat bar (4d-CoG-3p) does not change. This principle applies not only to the centre of gravity (CoG), as demonstrated in experiment 1 (Fig. 2 ABCD), but to any other point on the flat bar located above the rotation axis.

Concerning humans, the principles described above are similarly maintained (Fig. 4D). The point 4d furthest from the ground (the head) has the lowest value of the force of gravity (on a scale of the whole body), but it has the longest arm of the force of gravity. In the case of the 3p centre of gravity (on the lower leg), the force of gravity is much greater, but the arm of the force is respectively smaller (shorter) so that the moments of force in both cases are equal. When the body is tilted, the forces of gravity at individual points (from 4d to 3p) increase the closer they are to the axis of the upper ankle joint. The arm of the force decreases proportionally, therefore the torques remain unchanged at individual points. In the upright position, the arms of forces at points 4d to 3p are equal and amount to 0, hence the moments of gravity are also zero.

4.3 Balancing the torques in the human postural system.

4.3.1 Balancing the moment of gravity by the moments of the muscles in a double-sided lever system.

Based on the model of the human body (model 2), which is tilted at the "ankle joint" in the sagittal plane, measurements of the arms, gravitational forces, and the force of the "muscle" were made when the system was balanced (Fig. 5).

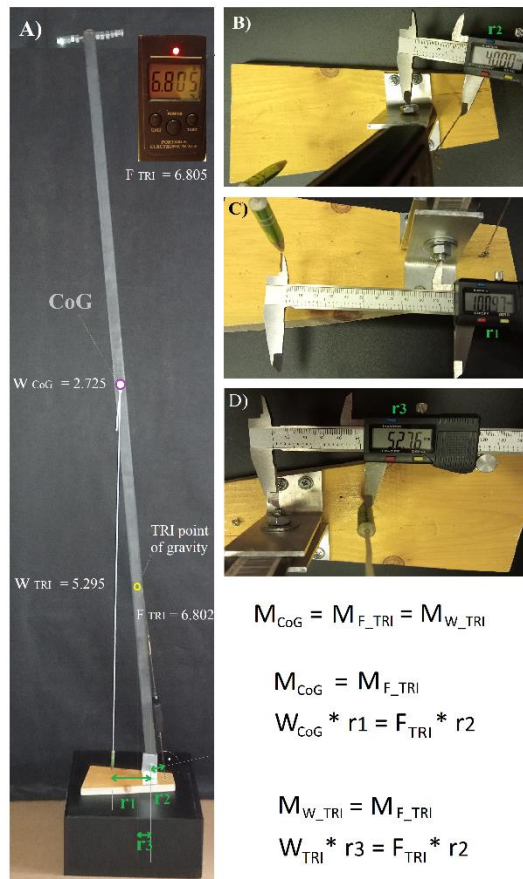

Figure 5. An example of balancing the moment of gravity of a tilted metal flat bar with the moment of the "triceps calf muscle" is presented in the model. A) Measuring system for simulating gravitational and muscle torques. CoG - the centre of gravity of the flat bar (55% of the distance from the ground), TRI point of gravity - a point halfway between the CoG and the ground (simulates the "proximal insert of the triceps surae muscle), W_{CoG} - the weight of the tilted flat bar at the centre of gravity, W_{TRI} - the weight of the tilted flat bar at the TRI point of gravity, F_{TRI} - the force of the triceps calf muscle balancing the moment of gravity at the CoG point (M_{CoG}) and in the TRI point of gravity (M_{W_TRI}), B) distance of the TRI action line from the axis of rotation (r_2), C) measurement of the arm of gravity for CoG (r_1), D) measurement of the arm of gravity for TRI point of gravity (r_3).

The experiment showed that the muscle moment M_{F_TRI} of 0.272 kGm at the same tilt angle balances the moment of gravity at the TRI point of gravity, which is $M_{W_TRI} = 0.275$ kGm. Slight deviations from balance are due to measurement errors. The same muscle moment M_{F_TRI} balances every other point on the tilted flat bar, including the centre of gravity CoG, because the moments of gravity for each point of gravity at a constant deflection angle are approximately the same (Table 3).

Table 3. Measurements of the flat bar gravity at the centre of gravity (W_{CoG}) and the TRI point of gravity (W_{TRI}), the strength of the triceps calf muscle (F_{TRI}), the arms of these forces r_1 , r_2 , r_3 , and the torques, i.e. M_{CoG} , $M_{F_{TRI}}$, $M_{W_{TRI}}$.

measurement	W_{CoG} [kG]	r_1 [m]	M_{CoG} [kGm]	F_{TRI} [kG]	r_2 [m]	$M_{F_{TRI}}$ [kGm]	W_{TRI} [kG]	r_3 [m]	$M_{W_{TRI}}$ [kGm]
m1	2.725	0.109	0.299	6.816	0.04	0.272	5.61	0.05	0.278
m2	2.731	0.09	0.245	6.805	0.04	0.272	5.005	0.056	0.282
m3	2.719	0.100	0.272	6.79	0.04	0.271	5.600	0.049	0.272
m4	2.733	0.098	0.267	6.811	0.04	0.272	5.159	0.055	0.283
m5	2.717	0.103	0.280	6.789	0.04	0.271	5.1	0.051	0.262
Mean	2.725	0.100	0.272	6.802	0.04	0.272	5.294	0.052	0.275

Since the weight of the tilted flat bar (W_{CoG} and W_{TRI}) and the arm of muscle force (r_2) are unchanged in the system, each change in the arm of gravity (r_1) is balanced by a corresponding change in the force of the triceps surae muscle (F_{TRI}). The greater the body tilt, the greater the TRI force (F_{TRI}).

4.3.3 Balancing the gravitational moment with the lifting moment in a one-sided lever system.

Based on experimental observations of a one-sided lever (Fig. 3), it was shown that as the flat bar is lifted, the value of the force of gravity at a given point does not change, but the gravitational moment changes and decreases with an increase in the angle of inclination of the flat bar.

An example of the action of a one-sided lever in the human postural system is the movement of the human body from a squatting position to an upright position. In this system, the gravitational force and the counteracting lifting force are on the same side of the rotation axis. Lifting the body reduces the arm of the gravitational force and the arm of the lifting force, and thus the moment of gravity and the moment of the lifting force decrease, down to zero values of the moments of force in the upright position (Fig. 6). The value of the gravitational force and the value of the lifting force do not change throughout the entire range of uniform motion.

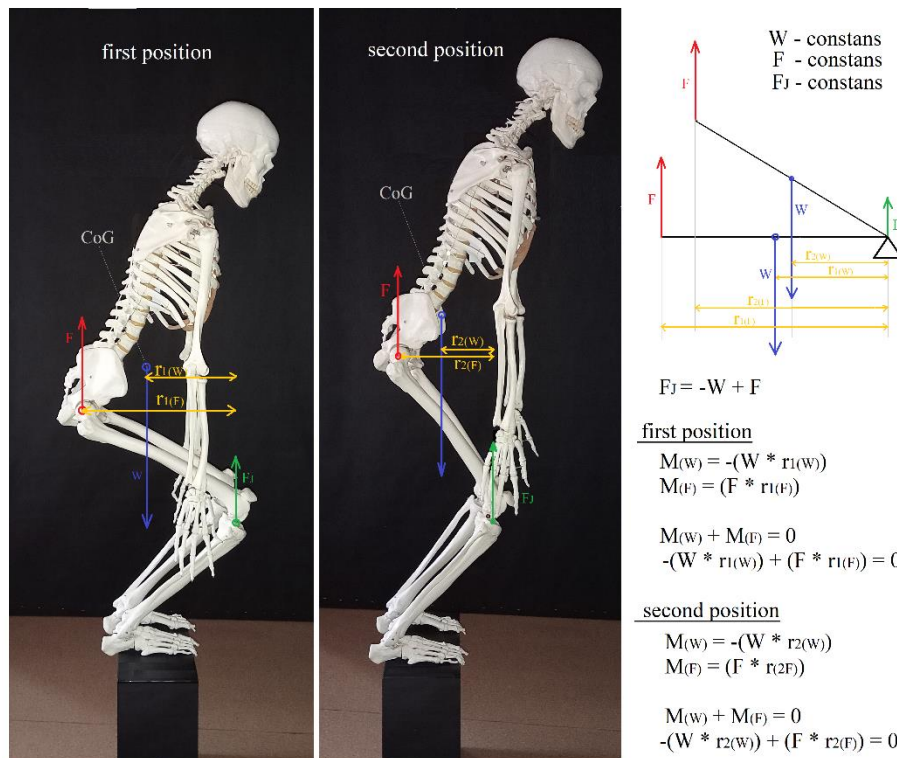

Figure 6. Forces and moments of the forces in the one-sided lever system on the example of the movement from a squatting position to a straight position. First position - the squatting position, Second position - the position of the raised body from the squatting position. In the squatting position, the force of gravity (W) and the net force of the anti-gravity muscles (F) are unchanged. The values of the arms of the gravity force ($r_1(W)$ and $r_2(W)$) and the values of the arms of the muscle's forces ($r_1(F)$ and $r_2(F)$) change. The opposite moments of muscular forces ($M(F)$) and gravitational forces ($M(W)$) are balanced at each stage of lifting the body. The values of these moments decrease as the body is lifted until they reach zero (the situation of positioning the knee in hyperextension in a standing position is neglected). CoG – the centre of gravity of the body.

The long femur provides a long lever arm in the squat position, thanks to which when lifting the body from the squat to the upright position, with a relatively small constant value of the lifting force, it is possible to lift the body with little energy expenditure of muscle.

5. Discussion

While pursuing the research goals, the paper indicates and proves that it is not the body weight (gravitational force) acting on the upper ankle joint and on the foot that is balanced by the muscle force (triceps calf muscle), but the moment of gravity that is balanced by the muscle

moment in the bilateral lever system. In addition, it was shown that the foot does not participate in the body tilting in a situation of full support by the feet, therefore its weight should not be included in the total body weight in such considerations. This is also associated with a higher centre of gravity than previously thought. The balance of torques and a higher centre of gravity are associated with higher values of muscle force and upper ankle joint pressure force than previously thought.

It is commonly believed that the tilting of the human body weight is balanced by muscular forces [17]. **It is not the muscular forces that balance the weight of the tilted body, but the sum of the muscular moments that balance the net moment of gravity.** In this situation, the value of the gravity force and the length of its arm are important, because the longer the arm, the greater the gravitational torque that the muscles must counteract.

When considering the "game" of torques, it is important to put them in the right context. Depending on whether they operate in a double-sided or one-sided lever system, the conclusions are different.

In the case of a two-sided lever system, the arms of the muscle force usually have a fixed anatomically defined length [7], while the muscle force is "regulated" by the number of activated neuromuscular units. An example of such a system is the tilting of the weight of the body in a standing position supported on the trochlea of the talus bone. The foot is not part of the weight of the tilting body. It is only a support, and therefore cannot be taken into account in measurements of the moment of gravity. Meanwhile, when determining the center of gravity of the body, the point of support (rotation) is set on the plantar surface of the foot (Du Bois-Reymond 1818-1896) [3][4]. In this approach, the human body is "seen" as a rigid body. **In real the point of support of the tilting human body is on the axis of the upper ankle joint,** so CoG is higher located. This has consequences in the analysis of muscle forces, and moments, as well as moments of gravity because a higher center of gravity increases the value of the gravity arm when the body tilts.

In the case of a one-sided lever system, the arm of gravity force and the arm of lifting force have a variable value, while the value of the lifting force and gravity force is constant. The body lifting from a full squat position to an upright position becomes easier and easier as you straighten it. This ease felt by proprioceptors is not related to the decrease in force values is a real decrease in both the moments of gravity and the balancing moment of lifting.

With the optimal structure of the human body, each centre of gravity in the body is at the optimal height. In such a system, correct muscle torque and gravitational torques are ensured with a physiological load on the articular surfaces lying below the given point of gravity. Pathological increase in body weight (e.g. in obese people) or shifting of the body's gravity points, e.g. by wearing high-heeled shoes, hurt the joints, which may lead to degenerative changes. This has to do with an increase in the force of gravity when your body weight increases and an increase in the arm of gravity when wearing high-heeled shoes. This increases gravitational moments at the joints below the gravity points [12]. In both cases, muscle moments must be increased by increasing muscle force to balance the moment of gravity, because the values of the arms of muscle forces at the level of individual joints generally have a constant value (these are two-sided lever systems). People of the same mass but shorter height have smaller gravitational moments than taller people. Taking into account that high torques significantly overload the joints, it can be concluded that taller people, as well as obese people, are more exposed to degenerative changes in the joints below the points of gravity. On the other hand, too low body weight causes underload of the skeletal system, which results in the development of osteoporosis [12]. In general, taking into account the torques generated in the upper ankle joint can help in understanding the biomechanics of the human body, which has not been taken into account in this approach so far [2, 18, 13] .

Knowledge of lever mechanisms in the human postural system will undoubtedly allow for the improvement in the approach to research on the biomechanics of the lower limbs as well as the conservative and surgical treatment methods.

6. Limitation

Analog models presented in the work allowed to show how important the gravitational factor is and how it affects the biomechanics of the foot. So far, models presented in the literature presented the not weight-bearing foot. The lack of "seeing" gravity resulted in the description of the movements of the not weight-bearing foot through the action of "pure" muscle force. Showing the action of the moment of gravity drew attention to the action of the muscle moment counteracting it. Experiments using analog models opened the way for considerations at a higher level of complexity of biomechanical systems. Without this stage, it would be difficult for biomechanical engineers to notice the relations between gravitational moments and muscle moments. Simulation studies in a computer environment can provide multidimensional data in a short period, which cannot be obtained based on analog models. In the future,

simulation applications could be an efficient tool for physiotherapists or sports coaches in predicting joint loads, as well as muscle energy expenditure.

7. Conclusion

In summary, the studies showed that taking into account the moment of gravity imposed "seeing" the muscle moment, and not just the muscle force, which changed the approach to analysing the biomechanics of the lower limb (a weak muscle with a large arm balances a strong muscle with a short arm). It was also shown that the foot supported on the ground does not participate in the body's centre of gravity swing. It is only a support platform. The CoG of the tilting body is higher, which is why greater torques are generated and the pressure forces on the joints are greater.

The conducted model tests showed that regardless of the angle of inclination, the value of body weight at the point that is the centre of gravity does not change. This rule also applies to any point of the tilted body. The next conclusion is that each inclination of the body generates a torque depending on the degree of inclination and is greater the greater the inclination. Moreover, for each of the points of gravity of the body, the values of torques at a given angle of inclination of the body have the same value. This means that the further the point of gravity is from the axis of rotation of a body tilted at a given angle, the smaller the weight at this point, but the greater the arm of force so that the moments of gravity are the same along the entire length of the tilted body. Additionally, for a tilting human body, the centre of gravity should be determined from the axis of the upper ankle joint, and not from the plantar side of the feet, because the feet do not participate in tilting the body, constituting only a platform with a support point on the trochlea of the talus bone.

Based on the experimental results, it can be concluded that the human body, while standing and moving, constantly strives to limit gravitational moments, which are balanced by muscle moments to optimize energy expenditure. This is manifested by striving to set the CoG projection in such a way that the arm of gravity is as short as possible.

Referencje

[1] Azar FM, Beaty JH, Canale ST Preceded by: Willis C. Campbell's operative orthopaedics. 14th ed. Elsevier; 2020.

[2] Babayi M, Mortazavi Najafabadi SM, Ashtiani MN, Grzelczyk D. General muscle fatigue changed

joint regulations in static and dynamic balance. *Acta Bioeng Biomech* 2023;25:125–32. <https://doi.org/10.37190/ABB-02293-2023-02>.

[3] Bewick GS, Banks RW. Mechanotransduction channels in proprioceptive sensory nerve terminals: still an open question? *Curr Opin Physiol* 2021;20:90–104. <https://doi.org/10.1016/j.cophys.2020.11.007>.

[4] Bober T, Zawadzki J. Biomechanics of the human movement system (Biomechanika układu ruchu człowieka). 1th ed. Wrocław: Bober, T Zawadzki, J; 2001.

[5] Dega W. Orthopedics and Rehabilitation (Ortopedia i Rehabilitacja). Wydawnictwo Lekarskie PZWL; 1983.

[6] Dygut J, Piwowar M. Torques in the human upper ankle joint level and their importance in conservative and surgical treatment. *Sci Reports* 2024 141 2024;14:1–13. <https://doi.org/10.1038/s41598-024-57698-4>.

[7] Hicks JH. The mechanics of the foot. IV. The action of muscles on the foot in standing. *Acta Anat* 1956;27:180–92.

[8] Le Huec JC, Saddiki R, Franke J, Rigal J, Aunoble S. Equilibrium of the human body and the gravity line: the basics. *Eur Spine J* 2011;20 Suppl 5:558–63. <https://doi.org/10.1007/S00586-011-1939-7/FIGURES/10>.

[9] Kapandji A. The Physiology of the Joints. 7th ed. Handspring Publishing; 2020.

[10] Kim DH, Park JK, Jeong MK. Influences of posterior-located center of gravity on lumbar extension strength, balance, and lumbar lordosis in chronic low back pain. *J Back Musculoskeletal Rehabil* 2014;27:231–7. <https://doi.org/10.3233/BMR-130442>.

[11] Levine D, Richards J, Whittle M, Whittle M. Whittle's gait analysis. 6TH ed. 2022.

[12] McInnes Spathopoulos V. An Introduction to the Physics of Sports. Gopublished; 2013.

[13] Obst SJ, Heales LJ, Schrader BL, Davis SA, Dodd KA, Holzberger CJ, et al. Are the Mechanical or Material Properties of the Achilles and Patellar Tendons Altered in Tendinopathy? A Systematic Review with Meta-analysis. *Sport Med* 2018;48:2179–98. <https://doi.org/10.1007/S40279-018-0956-7/FIGURES/5>.

[14] Pawłowski B, Grabarczyk M. Center of body mass and the evolution of female body shape. *Am J Hum Biol* 2003;15:144–50. <https://doi.org/10.1002/AJHB.10136>.

[15] Prochazka A. Proprioception: clinical relevance and neurophysiology. *Curr Opin Physiol* 2021;23:100440. <https://doi.org/10.1016/j.cophys.2021.05.003>.

[16] Roussouly P, Gollogly S, Nosedà O, Berthounaud E, Dimnet J. The vertical projection of the sum of the ground reactive forces of a standing patient is not the same as the C7 plumb line: A radiographic study of the sagittal alignment of 153 asymptomatic volunteers. *Spine (Phila Pa 1976)* 2006;31. <https://doi.org/10.1097/01.BRS.0000218263.58642.FF>.

[17] Silver RL, De La Garza J, Rang M. The myth of muscle balance. *J Bone Jt Surg - Ser B* 1985;67:432–7. <https://doi.org/10.1302/0301-620x.67b3.3997956>.

[18] Soodmand I, Keibach M, Ren X, Bruhn S, Tischer T, Bader R, et al. A musculoskeletal simulation study on the biomechanics of the lower extremity during the golf swing. *Acta Bioeng Biomech* 2023;25:177–88. <https://doi.org/10.37190/ABB-02316-2023-02>.

[19] Toyoda S, Haruyama A, Inami S, Arikawa T, Saito F, Watanabe R, et al. Effects of carvedilol vs

bisoprolol on inflammation and oxidative stress in patients with chronic heart failure. *J Cardiol* 2020;75:140–7. <https://doi.org/10.1016/j.jjcc.2019.07.011>.

ACCEPTED