

Sports biomechanics in the research of the Department of Biomechanics of University School of Physical Education in Poznań. Part 2. Biomechanics of rowing: research conducted in the rowing pool and under real conditions. Reconstruction and synthesis

LECHOSŁAW B. DWORAK*

University School of Physical Education, Poznań, Poland.

The purpose of this study was to reconstruct the early phase of scientific research conducted at the Department of Biomechanics of the College of Physical Education and since 1972 at the University School of Physical Education in Poznań, with special attention paid to the works on biomechanics of rowing, carried out as part of the Ministerial Project PR 105 entitled *The effectiveness of training, sports competition as well as regeneration in sports*.

Two kinds of biomechanical research are described: the several years' expert research conducted on the Rowing National Team in an original two-module Rowing Pool Testing Station BTW-1, as well as research on geometric optimization of the rowing station, conducted under real conditions, in reservoirs, with the use of a prototypical, unique at that time, computer measurement system BIOMIK, installed in the rower's own boat.

The projects were carried out by doctoral students from the Department of Biomechanics and the Department of Clinical Biomechanics, Andrzej Lisiecki and Wojciech Mikołajczyk, respectively.

Key words: biomechanics, rowing pool, kinematics and dynamics of rowing, criteria of rowing effectiveness, optimization

1. Formulation of the problem and the purpose of the study

Biomechanics of rowing was a dominating research problem in the period of 1970–1980 at the Department of Biomechanics. During the 1970's the school carried out the Ministerial Project 105 entitled *The effectiveness of training, sports competition as well as regeneration in sports*, and it was assigned the role of the coordinator of an extensive research on the Rowing National Team. A team of specialists in biomechanics led by Professor

Aleksander Kabsch, MD, cooperated intensively with a broad group of the University's scholars, conducting detailed analyses of physical and motoric potential, rowing technique and training of the rowers.

The purpose of this study was to analyze and document the scientific achievements of the employees of the Department of Biomechanics and the Department of Clinical Biomechanics in two types of research in the field of rowing biomechanics: research conducted in the rowing pool and research conducted under real conditions, i.e. in water.

As already mentioned in the previous publication [1] (where the author describes the phase of ergo-

* Corresponding author: Lechosław B. Dworak, Chair of Biomechanics, University School of Physical Education, Park Wilsona 1, 60-775 Poznań, Poland. E-mail: dworak@man.poznan.pl, Phone: 61 865 80 81.

Received: December 20th, 2009

Accepted for publication: February 20th, 2010

nometric research into neuromuscular coordination in rowing and the results of extensive research into kinematic and dynamic structure of rowing on the Universal Rowing Ergometer UEW-1), due to confidential clauses (in the expert opinion, the type of research) as well as the departure of several academic teachers from the Department of Biomechanics (A. Lisiecki, W. Lambui and W. Mikołajczyk), the materials that document the achievements of this range of study are virtually unobtainable.

These factors inspired the author to prepare this article and to publish it in English.

2. The project and research into the rowing pool – synthetic view

2.1. The first stage of research

Due to his project of the doctoral thesis, which aimed at creating, as an ultimate goal, a model of

biomechanical research in the rowing pool, the leader of the team, which conducted the expert research in the period of 1975–1978 and later, was LISIECKI [2], [3].

During the preparation of research in a rowing pool, an original idea of creating a modern measuring system was proposed, which in the subsequent phase was called the Rowing Pool Testing Station (*Basenowy Tester Wioślarski*) BTW-1 [2], [3]. The station in its first version (described by LISIECKI [2]) was equipped with the following instruments: electrical resistance strain gauges for the study of driving forces (stroke forces) due to the measurements of reaction forces at the oar handles, electrogoniometer for measurement of angular path of the oars by means of recording the movement of the oarlock, and potentiometer for recording linear movement of the sliding seat within the range of 0.7 m (figure 1).

The analysis of the forms of driving force impulses (conducted also, among others, by ISHIKO [4]) (figure 2) allowed formulation of several assessment criteria of rowing effectiveness, described in the papers of DWORAK et al. [5], [6] and LISIECKI [2], [3]. The estab-

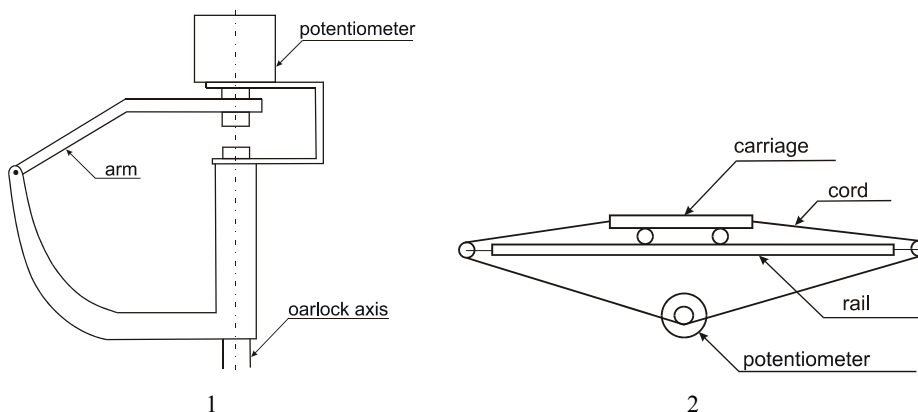

Fig. 1. Illustration of a prototype station for measuring biomechanical characteristics of rowing in the rowing pool: 1 – measuring oarlock, 2 – measuring carriage with seat and an attached potentiometer

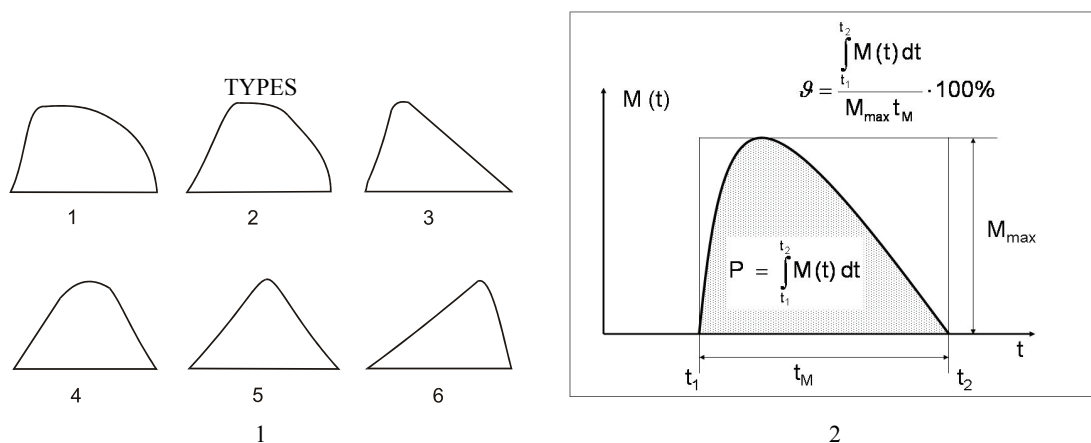

Fig. 2. Illustration of typical driving force impulse types (1) recorded during Lisiecki's tests (1975) and graphical representation of the filling factor (2) applied in the assessment criteria of rowing effectiveness

Table. Kinematic and dynamic parameters

No.	Parameter	Symbol	Unit
1	Number of measuring series	Z	(c)
2	Rowing speed	X	(c/min)
3	Angular path of the oar during the driving phase	Φ_{Fn}	(°)
4	Reaction force impulse measured at the handle (impulse of the force)	$F \times t$	(kps)
5	Driving force (stroke) duration	t_F	(s)
6	Mean value of the driving force	MF	(kp)
7	Maximum value of driving force	F_{max}	(kp)
8	Maximum force impulse	FT_{max}	(kps)
9	Dynamic efficiency of the rower	η	(%)
10	Effective mechanical work	L	(kpm)
11	Effective mechanical power	N	(W)

lishing of the criteria of rowing effectiveness in the rowing pool was inspired by a paper by FIDELUS and WYGANOWSKA [7].

The kinematic and dynamic characteristics of rowing in the pool were recorded with the use of the loop oscillograph N-117. 11 parameters, which are defined in the table, were analyzed.

2.2. The project and its realization in the Rowing Pool Testing Station BTW-1

The experience gained during the first phase of research in the rowing pool resulted in the modification of biomechanical testing methods and the creation of the Rowing Pool Testing Station BTW-1, described in detail in Lisiecki's doctoral thesis [3].

2.2.1. Basic assumptions

The following assumptions were made during the modification of the research project:

- a) the BTW-1 station is installed in the rowing pool as a single measurement station,
- b) it allows usage of modified short and long oars, taking into account the rowing side,
- c) it allows continuous recording and storage of the biomechanical parameters of the rowing cycle in the period of time that corresponds to the times achieved during a 2000-m rowing race, including the preceding warm-up,
- d) it allows controlling the effort of the rower during tests by verbal bio-feedback periodically in-

forming the rower tested about the values of driving forces currently produced.

2.2.2. Structure and function of the Rowing Pool Testing Station BTW-1

The BTW-1 measuring station had a two-module configuration. The measuring module consisted of a pool station for measuring biomechanical parameters of rowing and an electronic unit – the Dynamic Motion Parameter Analyzer (APD-1). The recording module consisted of a processing unit, two analog oscillographs N-117, and a video recorder (figure 3). A detailed configuration and the function of the modules are described in subsections 2.2.2.1. and 2.2.2.2.

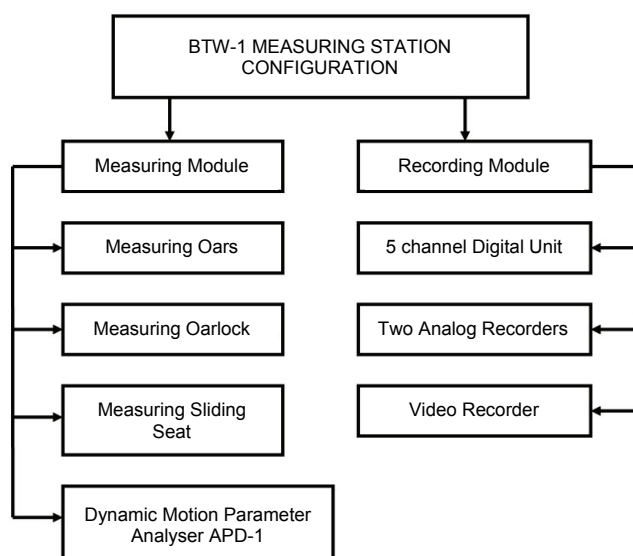

Fig. 3. Schematic diagram of the Rowing Pool Testing Station BTW-1

2.2.2.1. Measuring module

This module consisted of the following elements:

a) Measuring oars. Experience gained in the previous phases showed that the shape, the weight and the length of the oars, as well as the design of the strain gauge had to be modified and an additional sensor had to be used (figure 4).

The driving-force transducer consisted of a steel plate encased in a metal cover. It contained semiconductor strain gauges and was attached to the oar handle. As a result, hysteresis effect was minimized, and linear characteristics of forces recorded with time were achieved.

A special post (figure 5) was created for static calibration of the channel used for the measurement of the driving forces acting on the oar. It could be used to load

the oar supported by the oarlock (rotation axis) with calibration weights. The point of suspension of the weights was in the centre of the oar blade, and the handle was blocked in the middle of its grip zone. Forces, acting – in relation to the axis of the oarlock – on the x arm, in fact, generated driving moments M studied during the stroke phase (figure 6). They were recorded in the Rowing Pool Testing Station (figure 6).

Additional contact sensor, which monitored the time of the oar blade submersion in water, was attached to the distant bottom part of the oar blade. The operating principle of the sensor consisted in changes in electrical resistance in contact with water medium. The sensor produced a gating signal, making it possible to count a driving phase (generated torque), provided that the oar is pulled while submerged in water. By that means, the runs when

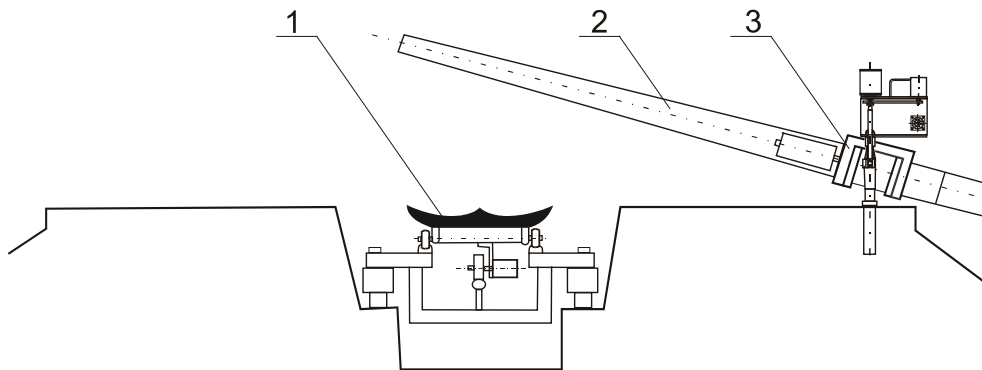

Fig. 4. Schematic diagram of the pool station for the measurement of biomechanical parameters of rowing:
1 – sliding seat with motion sensor, 2 – measuring oar with strain gauge, 3 – measuring oarlock attached to the oar

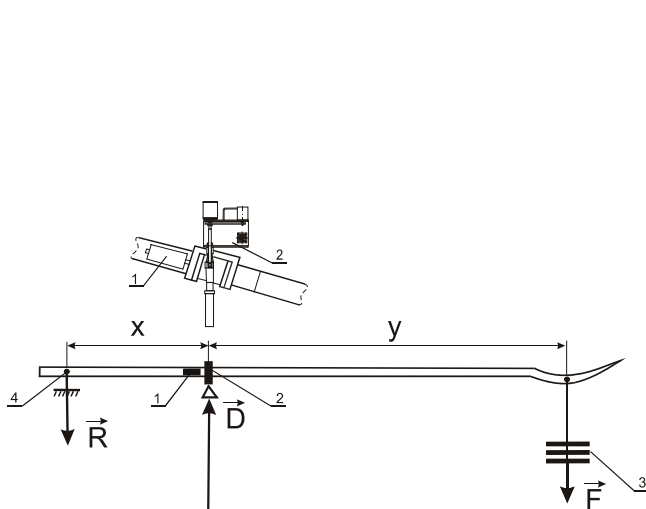

Fig. 5. Illustration of the strain gauge calibrating procedure used for the measurement of driving forces (torques) acting on the oar:
1 – strain gauge, 2 – oarlock, 3 – calibration weights (F),
 D – reaction force on oarlock, R – reaction force on oar blocking system

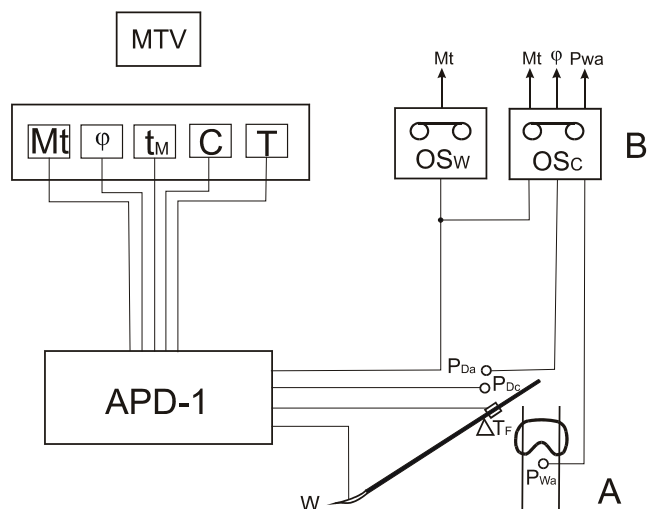

Fig. 6. Schematic of the Rowing Pool Testing Station BTW-1

the oar was not in the water during the stroke were not counted.

b) Measuring oarlock. A linear potentiometric sensor of angular oar motion was used. It was fixed with a fastener to the oarlock. The angular oar motion recording system was significantly modified in relation to the previous phase of research, by using two independent measuring channels: an analog and a digital one. Analog recording was carried out with a potentiometric coil converter, which was connected with a belt transmission to the next converter – an analog-digital converter (NPL-10 type: 100 impulses/radian), for digital recording of oarlock rotation (figure 7).

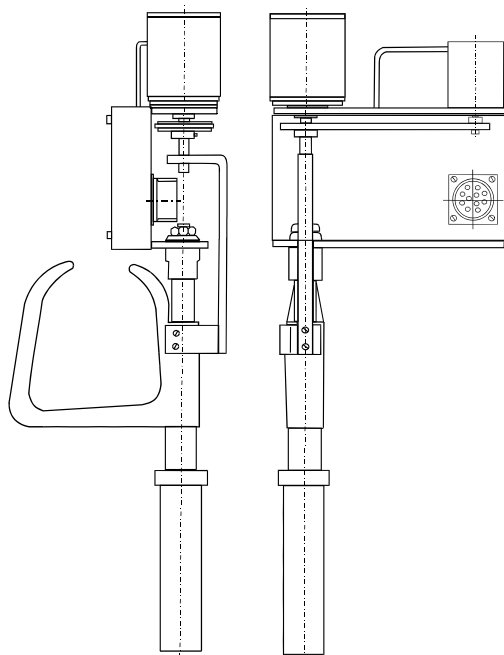

Fig. 7. Measuring oarlock used in LISIECKI's research [3]: view in two planes

c) Measuring sliding seat, designed in a similar way as the one used previously, e.g. in the UEW-1 (figure 1).

d) Dynamic Motion Parameter Analyzer APD-1 (figure 6). This unit consisted of: an extensometric bridge and its calibration system, a frequency converter to change the voltage, impulse linear and angular motion transducer, additional gating circuit, central control unit, internal clock and power supply unit.

The input signals to the APD-1, doubled and independently scaled, were analog time graphs of driving torques M , angular motion of the oars φ (from the measuring oarlock) and the gating signal B (see the above description of the measuring oars).

2.2.2.2. The recording module

The recording module consisted of:

a) 5-channel digital unit (5-digit displays CPO 4507, POLAM), for reading the values of such parameters as: rowing time T , maximum driving force F_p , total driving torque ΣMt (accuracy of 10 Nms), total time of driving torque development Σt_M (accuracy of 0.01 s), total range of angular path of the oar $\Sigma \varphi$ (accuracy of 0.01 radians). The recording time limit was 10 minutes.

b) Two analog recorders (N-117), one of them, with fast tape feed (50 mm/s), recorded driving torque characteristics as well as oar and sliding seat motions, and the other, with slow tape feed (1 mm/s), recorded the driving torque – the time curve for the entire duration of the measurement experiment.

APD-1 provided measurement input signals to the digital unit and the analog recorders.

c) Video recorder (SONY, AV-3670 CE). Due to the unreliability of the printers, digital data displayed in the processing unit was continuously recorded. In this way, large collections of data could be stored, and then used for analyses and studies.

The results of this phase of research allowed the author (LISIECKI) [3] to formulate modified (in comparison to those provided by DWORAK et al. [5], [6], LAMBUI and LISIECKI [8], LISIECKI [2]) assessment criteria of rowing effectiveness (elements of motion technique and dynamics of effort) on the ergometer and in the pool. Their character is presented in the following subsection.

2.2.3. Assessment criteria of rowing effectiveness in the pool

For the purpose of disambiguation, some of the criteria have been slightly modified in relation to the original ones. Only the criteria related to rowing in the pool are listed. They are as follows:

1. The criterion of maximum moment of driving force impulse at the oar handle

$$M = r \int_{t_1}^{t_2} D(t) dt \rightarrow \max ,$$

where:

M – the impulse of force,

D – the vertical component of the driving force acting on the oar handle,

r – the arm of the force D in relation to the rotation axis of the oarlock,

t_M – the time ($t_M = t_2 - t_1$) of the driving force acting on the oar handle.

2. The criterion of maximum moment of average driving force (M_{av}) acting on the oar handle

$$M_{av} = \frac{r}{t_M} \int_{t_1}^{t_2} D(t) dt \rightarrow \max .$$

3. The criterion of maximization for the maximum moment of the driving force (M_{max}) acting on the oar handle

$$M_{max} \rightarrow \max .$$

4. The criterion of maximum mechanical work (W) of a rower during one rowing cycle

$$W = M_{av} \varphi \rightarrow \max ,$$

where:

W – the mechanical work of a rower during one cycle,

φ – the angular path of the handle during the driving phase,

M_{av} – as in criterion 2.

5. The criterion of maximum mechanical power (P) of a rower during one rowing cycle

$$P = \frac{W}{t_M} \rightarrow \max .$$

6. The criterion of maximum value of the filling factor (\mathcal{G})

$$\mathcal{G} = \frac{\int_{t_1}^{t_2} M(t) dt}{M_{max} t_m} \cdot 100\% \rightarrow \max ,$$

where $\max = 100\%$.

7. The criterion of minimum rise time (t_n) of the moment of the driving force impulse M at the oar handle

$$t_n \rightarrow \min .$$

8. The criterion of minimum decay time (t_{op}) of the moment of driving force impulse M at the oar handle

$$t_{op} \rightarrow \min .$$

9. The criterion of optimum angular path of the oar handle during the driving phase

$$\varphi \rightarrow 90^\circ ,$$

where the angle $\varphi \in [45^\circ, -45^\circ]$.

10. The criterion of minimum asymmetry of the angular path of oar handle during the driving phase

$$\varphi_R - \varphi_D \rightarrow 0 ,$$

φ_R (φ_D) is the angular path of the oar handle at the stern (bow) of the boat, where the reference line for these angles is perpendicular to the long axis of the boat.

11. The criterion of optimum time (t_{Mopt}) of generating driving torque at the oar handle

$$t_M \rightarrow t_{Mopt} ,$$

where $t_{Mopt} \in [0.81, 0.88]$ s.

2.2.4. Summary of research in the rowing pool

The research conducted on rowers, described by LISIECKI [2] in the way similar to that of the later research and conducted on the Rowing Pool Testing Station BTW-1 [3] was designed first of all for identification and application purposes. Based on the values of the parameters studied and taking into account the assessment criteria for the effectiveness of rowing technique and energetics, rower rankings were created. Furthermore, the team of coaches was offered the suggestion that in the selection of rowers for boat crews the similarity of the biomechanical characteristics analyzed had to be taken into account.

When the research was continued after 1975, experience gained during this subsequent phase was used to introduce additional solutions – a significant modification in the oar design (as a result of an interesting cooperation with a boatbuilder) and the way of attaching strain gauges (directly to the oar handle, without the use of the steel plates). The recording module was also modified (figures 3 and 5) due to eliminating the previously used video recording of test results by implementing an additional electronic control panel.

During the tests on the BTW, two PhD dissertations were prepared, one on biomechanics and one on physiology. Several MSc. dissertations and several papers of students from the Biomechanics Section of the USPS Students' Scientific Club (SSC), under the supervision of L.B. Dworak, PhD, were written. These papers were presented at international SSC conferences of universities of physical education (Budapest, Prague).

The expert research on the BTW-1 was conducted by: A. Lisiecki, A. Kabsch, J. Cabański, L.B. Dworak, R. Gendera, W. Lambui, H. Parysek, and W. Mikołaj-

czyk. They were helped by students of the SSC and MA students from the Department of Biomechanics.

3. Research under real conditions

3.1. The project of optimization research by W. Mikołajczyk – synthetic view

The experience gained in the final years of the expert research on biomechanics of rowing (unpublished and handed over only in the form of periodic reports to the coaches and the PR 105 project coordinator) was for W. Mikołajczyk, MA, a junior lecturer at the Chair for Clinical Biomechanics, an inspiration for formulating an original project of a doctoral thesis, which addressed the problem of optimizing the rowing station. In 1987, he completed a paper entitled *Geometric optimization of the rowing station* [9], which was supervised by Prof. A. Kabsch, MD.

The purpose of this thesis was to verify 4 research hypotheses on individual technique of rowers, taking into consideration individual characteristics of rowers and oars in the selection of geometric parameters of boats, optimal location of the oarlock in order to take advantage of the current motoric potential of the rowers, the factors considered in the optimization method.

3.2. Measuring stations

The author decided to employ an original and innovative research method, by using a measuring station in the following configuration (figure 8): measuring channel of force and angular position of the oar in the form of a special measuring oarlock (figure 9) and a measuring computer.

The author made the following assumptions: the recording of biomechanical characteristics of rowing should be performed during rowing in the rower's own boat, with equipment normally used during competitions; the station can be installed in any long oar rowing boat.

In order to carry out the research project, W. Mikołajczyk and J. Cabański (Chair for Clinical Biomechanics) designed and built a measuring minicomputer BIOMIK V 3.0, which was based on the Z-80A microprocessor. BIOMIK featured 117 KB of RAM, a real time clock, systems for cooperation with: a keyboard, a display unit, recording units in the form of

a printer and a tape recorder and mass storage. The input signals to the BIOMIK (figure 8) came from measuring channels from the oarlock (the force C_f and angle C_k). The measurement was started with the push of a button in the control terminal CT (figure 8). The station was powered from one source – a battery. The total mass of the station, including the battery, was less than 8 kg.

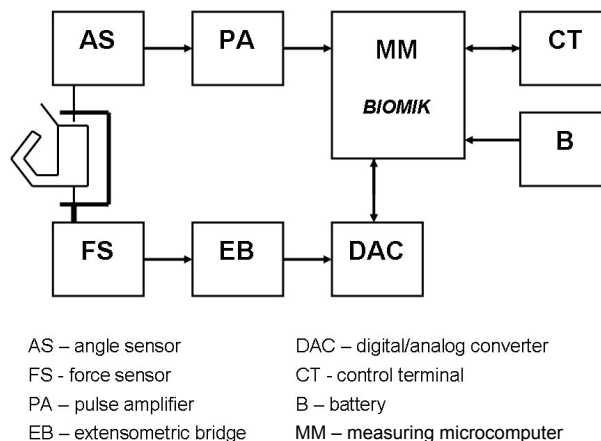

Fig. 8. Schematic diagram of the rowing measuring station, MIKOŁAJCZYK [9], adaptation of the figure

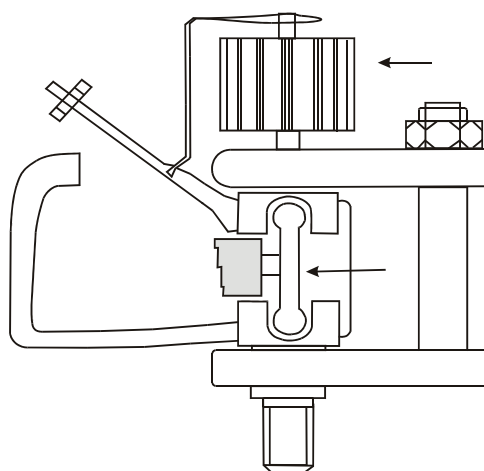

Fig. 9. Measuring oarlock, MIKOŁAJCZYK [9], adaptation of the figure

The measuring oarlock was designed, according to the recommendations of BIOMIK's authors, by J. Radziejewski, MEng, and produced at the Department of Research Materials, USPS. The "Karlsh" type model was used in the production.

3.2.1. Force measurement

In the place of the rotation axis of the oarlock, a force transducer was used C_f (a steel plate with semi-

conductor strain gauges). The oars acted on it through an element which transmitted pressure. The output signal from the force sensor was amplified with a hybrid direct current bridge (IA/05 type) and digitized with an 8-bit analog-digital converter (ZN 437 type). Due to hard environmental conditions (humidity, changes in temperature), the sensor was covered with a silicone coating. Regardless of this protection, these conditions can be verified by a software method and necessary corrections introduced. A measuring error in the force measuring channel was <0.5 bit, i.e. less than 0.2%.

3.2.2. Angle measurement

After some experiments, the authors decided to use an MPL digital impulse sensor (peak resolution of 1000 pulses/min) to measure the angle. This solution resulted in very satisfactory resolution of angle measurement, whose error was less than 0.2° . The sensor for angle measurement was installed on the oarlock (figure 9) to record its position.

Due to the fact that the most important factor in force distribution (figure 10) is the angle between the vertical component R and the direction of boat motion, the corrections to the angle of the oar blade plane and the oar deflection angle were introduced; more details can be found in the paper [9]. The symbols used in this paper do not correspond to the ones used previously.

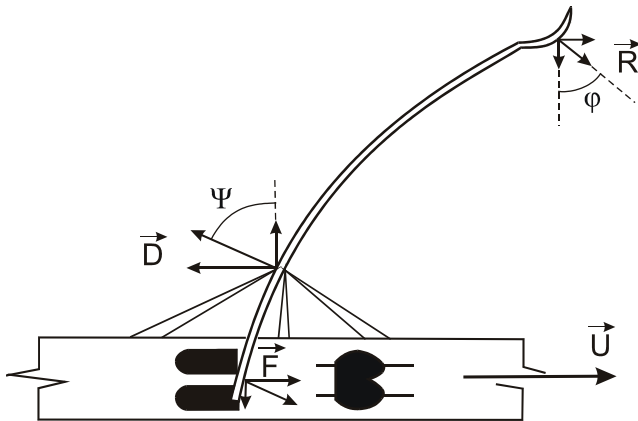

Fig. 10. Distribution of forces R , D and F into components, MIKOŁAJCZYK [9], adaptation of the figure

3.2.3. Measurement control during sailing

Measurement control had a two-phase character. The first-phase measurement was carried out at the pier and consisted in starting the "program for monitoring oar position – from vertical position to the side of the boat".

In the second phase, real measurement of the characteristics studied (gathering data) was conducted. This phase could be started by pushing the button at the control terminal CT (figure 8), or with using the remote-control system. The starting resulted in the commencement of recording until: the time when a specific number of rowing cycles were performed, another pushing of the CT button, or the moment the memory of the minicomputer was filled. The measuring capacity of the system was designed for about 400 driving phases.

3.2.4. Computer programs used

The entire work was possible thanks to the creation of four original computer programs by W. Mikołajczyk.

The first one served the purpose of collecting data in the rowing boat: machine language of the Z-80 microprocessor, adapted to BIOMIK, and its measuring channels.

The second one calculated the values of the following parameters:

a) kinematic ones in the form of: rowing speed and rhythm, duration of recovery and stroke phases, angle at which the maximum force of stroke occurred, initial and final angles (of putting the oar in and taking it out of water), the angular range of the oar motion, the correction of oarlock axis position in relation to the foot rest;

b) dynamic ones in the form of: the maximum force produced, the mechanical work performed, work during a rowing cycle, work during one minute of rowing, effective work, effective work per one cycle and one minute of rowing, the asymmetry of the work performed, theoretical maximum effective work per rowing cycle – taking into account corrections.

The third program allowed tabular comparison of the values of the most important parameters used for statistical analysis.

The fourth program was used for the analysis of the statistics used in the work.

Measurements with the use of the computerized measuring station installed in the rowers' own boats were performed in two series. 2 juniors and 4 seniors from Poznań city sports clubs (the river Warta, Sep./Oct., 1986), participated in the first series, and 8 female rowers of the junior Polish National Team (Olympic Preparation Center in Wałcz, Oct., 1986) in the second one. Lisiecki participated in the measurements.

3.3. The most important conclusions of the optimization research

In 14 conclusions presented in the paper, the research hypotheses described and the purposes of the study were positively verified.

The author observed, among other things, that: the rowing style of the rowers (expressed by stroke torque with time in relation to the position of the oar) does not depend on the position of the foot rest and the oars used; the optimal positioning of the rotation axis of the oarlock in relation to the foot rest enables the rowers to achieve higher values of effective work; optimization of the oarlock position should be carried out “by changing the geometry of the outrigger”; the gain of effective work described in the paper caused by optimization of oarlock position allows one to anticipate a gain of average rowing speed of around 2%, which represents a gain of approximately 40 m at a distance of 2000 m; the method proposed allows an advanced assessment of the physical training level of the rowers, the analysis of rowing technique errors and suggestion on how to correct individual technique, it also enables one to select the rowers for the crews.

4. Summary

Biomechanics of rowing, studied in several research projects of the employees at the Department of Biomechanics and later at the Chair for Clinical Biomechanics, was a leading research problem during the decade of the 1970s, although it originated a little earlier. Looking back at it years later, the author assesses this long period of scientific cooperation of the large group of academic workers and technical workers both from the Department itself and from other departments of the University as exemplary.

As far as the long-term research conducted in the rowing pool is concerned, especially the one with the use of the Rowing Pool Testing Station, one should stress its expert character and its logistic complexity, which both were a challenge for the entire team. This challenge consisted in the studies of an elite group of male and female rowers, it released great intellectual potential shown in the original modifications of the prototype testing equipment, the selection of representative parameters for the assessment, a successful but not straightforward cooperation with the national team coaches environment, etc.

A darker side of this period of scientific activity was a scarce funding of the research based on very odd rules, which, with its complex logistics and imposed deadlines interfering with regular lecturing activity and other responsibilities, were not satisfying to anyone. Moreover, there was a shortage of papers, which were published in Polish with delay and almost exclusively in non-serial publications – monographs – with a very limited reach. This was partly influenced by secrecy clauses of the expert research results and a limited publishing cycle, after the fact.

The results of this several years’ periodic research, conducted on leading rowers of the Polish National Team, were: an original measuring station characterized by a large degree of reliability, despite the extreme working conditions and unfavourable environment (water, humidity), which could compete with the ones used at that time around the world, expert opinions presented to the coaching teams, and publications which contained the original rowing effectiveness assessment criteria. The expert research was continued until the 1980’s and its results were presented to the coaches and the Project coordinator, unfortunately without being published in periodicals.

For the original achievements being related to the implementation of the BTW-1 measuring station (additionally modified in the third phase of the research) in the expert research conducted on the rowers taking part in the Central Training Program, the Team composed of: Prof. A. Kabsch, MD, A. Lisiecki, PhD, and W. Lambui, MEng, received a Level 2 Award of the President of the Youth and Physical Culture Committee.

The character of the project connected with the doctoral thesis of W. Mikołajczyk was slightly different. It was carried out a decade later, innovative and original, advanced both methodologically and technologically, and aimed at important problems of optimization [9]. Unfortunately, it has not been implemented in the systematic expert research conducted on the rowing national team.

During the research carried out on the rowers, 3 dissertations were written, all related to doctoral theses, including 2 theses about biomechanics. Several master’s theses and several student papers were prepared, related to the activity of the Students’ Scientific Club.

After the completion of the Ministerial Project PR 105, the research on the rowers was taken over by a team of the workers from the Sports Institute in Warsaw, who proposed a different and original methodology that was periodically modified. The team implemented modern measuring channels, taking advantage of the newest technologies.

Acknowledgements

This research project was financed from a fund for the statutory activity of the Chair of Biomechanics.

The author would like to thank his colleagues: A. Lisiecki, PhD, and W. Mikołajczyk, PhD, for granting access to the data included in their doctoral theses and to K. Kmiecik, MEng, and J. Mączyński, MA, for their help in the preparation of illustrations and technical editorial work.

References

- [1] DWORAK L.B., *Sports biomechanics in the research of the Department of Biomechanics of University School of Physical Education in Poznań*. Part 1. *Biomechanics of rowing: tests on rowing ergometers, reconstruction and synthesis*, Acta of Bioengineering and Biomechanics, 2010, Vol. 12, No. 1, 55–64.
- [2] LISIECKI A., *An attempt to assess the rowers taking part in the Central Training Program on the basis of selected kinematic and dynamic parameters measured in the rowing pool*, Monograph No. 61, Research Results. Wioślarstwo (Rowing) III, USPS, 1975, 37–62.
- [3] LISIECKI A., *Optimal model of rowing technique in the rowing pool*, Doctoral Thesis, USPS in Poznań, typescript, 1979, 109 pp.
- [4] ISHIKO T., *Biomechanics of rowing*, [in:] J. Vredenberg and J. Wartenweiler (eds.), *Biomechanics II*, Med. Sport, 1971, Vol. 6, 249–252.
- [5] DWORAK L.B., KABSCCH A., LAMBUI W., LISIECKI A., *Description of selected kinematic parameters in athletes taking part in the Central Training Program*, Research Results, Wioślarstwo (Rowing) III, Assessment of the rowing training in the 1973 season, USPS in Poznań, Monograph No. 61, 11–28.
- [6] DWORAK L.B., KABSCCH A., LAMBUI W., LISIECKI A., *Description of selected kinematic parameters in athletes taking part in the Central Training Program*, Research Results, Wioślarstwo (Rowing) III, Assessment of the rowing training in the 1973 season, USPS in Poznań, Monograph No. 61, 29–36.
- [7] FIDELUS K., WYGANOWSKA A., *The distribution of horizontal components of forces and velocity and the assessment of rowing effectiveness in a single scull*, [in:] *Symposium Teorii Techniki Sportowej (Sports Technique Theory Symposium)*, Warsaw, Sports and Tourism, 1970, 61–71.
- [8] LAMBUI W., LISIECKI A., *The attempt to formulate biomechanical criteria for the assessment of the rowing technique in a pool*, Scientific Symposium “Sports Training Control Methods”, Scientific Bulletin of the USPS in Wrocław, B. 23, 1977, 127–142.
- [9] MIKOŁAJCZYK W., *Geometric optimization of the rowing station*, Doctoral thesis, USPS in Poznań, typescript, 1987, 76 pp.