

Sports biomechanics in the research of the Department of Biomechanics of University School of Physical Education in Poznań. Part 1. Biomechanics of rowing: tests on rowing ergometers, reconstruction and synthesis

LECHOSŁAW B. DWORAK*

University School of Physical Education, Poznań, Poland.

The purpose of this study is to reconstruct the early phase of scientific research conducted at the Department of Biomechanics of the University School of Physical Education in Poznań, particularly the work on biomechanics of rowing, conducted as part of the Ministerial Project PR 105, entitled "The effectiveness of training and competition as well as regeneration in sports".

Three kinds of research have been described, carried out with the use of the rowing ergometers. The first was the research on neuromuscular coordination in the rowing cycle, the second was the research on kinematic and dynamic characteristics of rowing on the Universal Rowing Ergometer UEW-1, while the last one concerned determination of maximum forces generated by functional muscle groups in two characteristic rowing positions within the closed biochain of the torso and the limbs.

Key words: biomechanics, rowing ergometers, neuromuscular coordination, kinematics and dynamics of rowing

1. Problem formulation

1.1. Genesis of the Department of Biomechanics and its goal – synthetic presentation

Department of Biomechanics of the University School of Physical Education in Poznań has its roots in the Department of Anatomy and Biomechanics, created on December 15, 1951 at the Faculty of Physical Education of the then Higher School of Physical Education (HSPE).

The first director of this unit, which was created within the structure of the Department of Biological

Sciences (1951–1958), was Feliks Kamiński, MD, graduate of the Faculty of Medicine, Medical Academy (1927), as well as graduate of the College of Physical Education at the University of Poznań (1932).

Professor F. Kamiński was the chancellor of the HSPE in Poznań (1951–1956). As early as in the 1930's, he lectured on anatomy with elements of the mechanics of motion – biomechanics, within the physical education study program (of the then University of Poznań). It is assumed that he was the first academic teacher of biomechanics in Poland [1]–[4]. After the death of Prof. F. Kamiński (1958), the Department of Anatomy and Biomechanics was headed by J. Kołaczkowski, MD, Ph.D. (1958–1965).

An independent Department of Biomechanics was created on March 1, 1965. It was headed for about

* Corresponding author: Lechosław B. Dworak, Chair of Biomechanics, University School of Physical Education, Park Wilsona 1, 60-775 Poznań, Poland. E-mail: dworak@man.poznan.pl

Received: December 20th, 2009

Accepted for publication: February 20th, 2010

3 years by Józef Kołaczkowski, MD. After Aleksander Kabsch, MD, received the scientific degree of habilitated doctor in 1968, he was entrusted with the function of the head of the Department [1], [2], [4]. In 1991, the Department of Biomechanics for the first time received the status of a Chair, and was headed by Prof. A. Kabsch, MD, Dr. hab. In the following years it went through several transformations. Professor A. Kabsch was the chancellor of the USPS in Poznań during the period of 1981–1985.

During the period of 1992–2002, due to the adoption of institute structure of the Faculty of Physical Education, two independent Departments of Biomechanics were created. Department of Clinical Biomechanics, headed by Professor A. Kabsch, was situated within the structure of the Institute of Rehabilitation, and Department of Biomechanics, which was headed by the author, was affiliated to the Institute of Physical Education and Sports. After Professor A. Kabsch finished his work at the USPS (2001), there is one Department of Biomechanics within the organizational structure of the University – within the Faculty of Physical Education, headed by the author (figure 1).

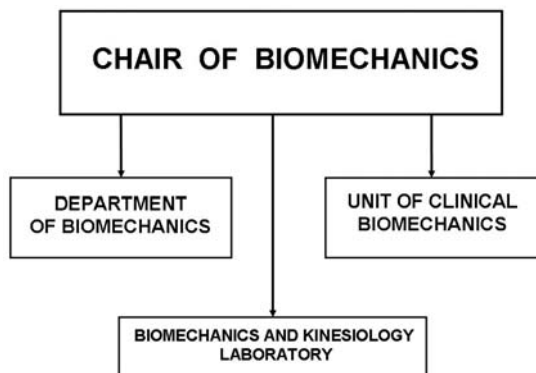

Fig. 1. General diagram of the structure of the Department of Biomechanics at the USPS in Poznań, as of 2009

The Clinical Biomechanics Unit presented in this model is an equivalent of the Department of Clinical Biomechanics, previously headed by Professor A. Kabsch.

The purpose of this study is to analyze and document the scientific achievements of the employees of the Department of Biomechanics, especially the ones concerning the biomechanics of rowing and the beginnings of scientific activity. Materials that document the works of this scope of research are virtually unobtainable, which in the case of rowing biomechanics is due to the restrictions imposed on publishing original research results, obtained from their expertise.

2. First scientific works in the field of biomechanics

The beginnings of scientific activity of research and academic workers in the field of biomechanics are related to three doctoral theses. The ones of Aleksander Kabsch, MD, Seweryn Toboła, MA, and Edmund Gniewkowski, MA, MD, all employees of the Department of Anatomy and Biomechanics. Later on, the habilitation thesis of A. Kabsch, MD was also influential. One may distinguish two fields of study:

1. Sports biomechanics of disabled persons, especially ski elements in persons after amputation as well as gait analysis [5] and biomechanical gait analysis in persons after amputation rehabilitated during ski camps [6].

Both research subjects shared a common methodology: the application of biomechanics cinematography (with the use of electrically driven film camera Pentaflex 16) and photometry – for the analysis of kinematic parameters, general medical and orthopedic examinations, research material consisting of participants after amputations above and below the knee joint, rehabilitation method in the form of skiing training, particularly downhill skiing, logistics of research, which was carried out during several rehabilitation camps two times, at the beginning and at the end of the camp.

In the doctoral thesis (52 participants were tested altogether) 22 detailed conclusions were formulated. Part of them concerned compensatory mechanisms that occur in locomotion control and in some skiing positions, depending on the level of limb amputation. The issues addressed in the research associated with the doctoral thesis of A. Kabsch were at that time pioneering. The gait analysis technique consisted in cinematographic recording of locomotion. The in-profile films (filming frequency of 24 fps) were made at the State Prosthesis Manufacturing Plant in Poznań, with the use of a camera moving on a trolley, which followed the motion of the participants. Kinematic analysis of the gait was carried out with the use of a film viewer (figure 2).

In the habilitation thesis (21 participants were selected according to their skill in skiing, including 3 females), 42 parameters were analyzed. They were assessed two times, during tests carried out before and after the camp. The gait of the participants was filmed (characteristic points of body segments were properly marked) in two planes, with the frequency of 32 fps. Pentovar zoom lens was used with the focal length of

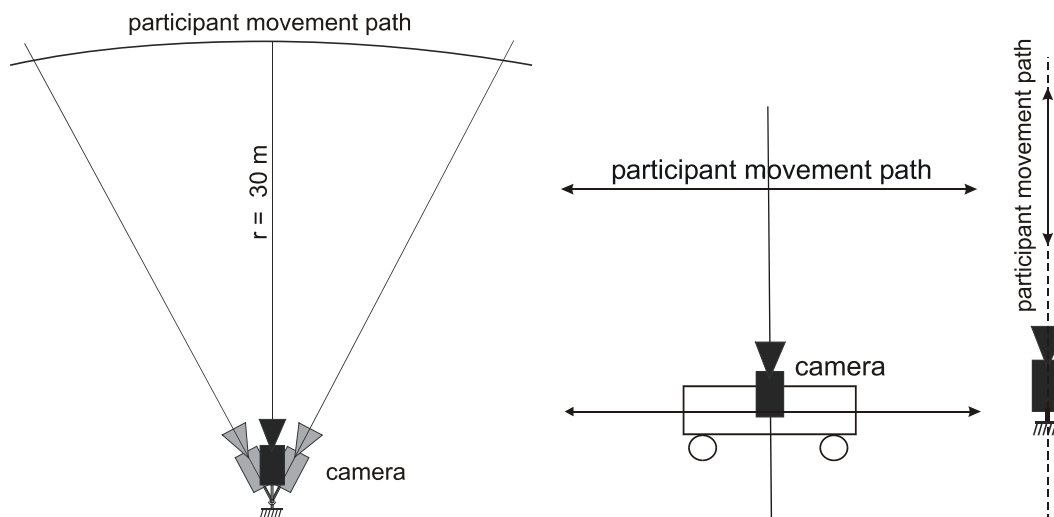

Fig. 2. Schematic diagram of cinematographic tests used in the works of A. Kabsch

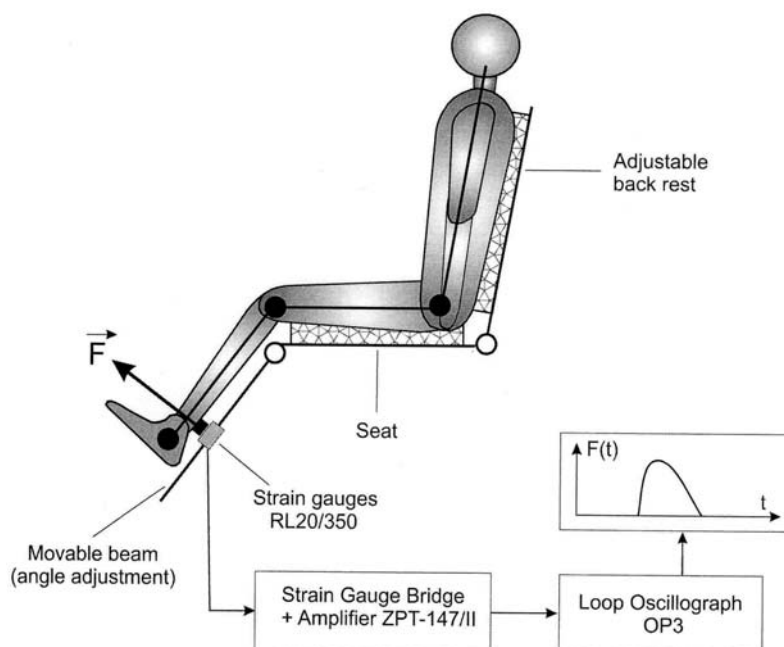

Fig. 3. Schematic diagram of the TO-60 measurement station, with the modification of the measurement path, used in the research of Gniewkowski (1968)

120 mm and the filming accuracy of $\pm 6\%$. For the analysis of the motion in the sagittal plane panoraming filming technique was used along a curve with a 30 m radius. For the frontal plane the motion of participants coming closer and going away from the camera was filmed (figure 2). In a special darkroom, located in a room of the Department of Biomechanics, a measurement analysis stand was set up. It was equipped with a mechanical film transport projector that had a frame freeze function. 30 full gait cycles were analyzed for each plane. The evaluation covered: time structure of the gait cycle phases, oscillation of

selected markers, support surface width, general center of mass amplitude in the sagittal plane. The work formulated 3 general and 15 detailed conclusions.

The conclusion in both projects consisted in a clear statement that skiing is a valuable form of rehabilitation for people after amputations.

2. The search for the relationship between torque generated by knee joint extensors and flexors and the angular position of the neighboring joints. The ideas behind these research projects were inspired by A. Kabsch, MD. They were original, empirical, applicable especially in rehabilitation and biomechanics-

kinesiology (measurement of mechanical muscle characteristics), coincident with the interests of a wider group of specialists in biomechanics, also outside Poland [7]. This research was possible owing to the construction of the then unique measurement station with variable geometry of support and variable geometry system for transferring force to the sensors, created by TOBOŁA and JANOWICZ [8]. The station was equipped with a spring dynamometer. In the research of Gniewkowski it was modified by using a new measurement path with a converter and a strain gauge amplifier (strain gauge beam equipped with specially shaped profiles for transmitting the force from the body segment – shin – to the sensor, (figure 3)). The modifications were described in papers [9] and [10]. During the decade of 1990's, the station was transferred to the Biomechanics Laboratory of the External USPS Faculty in Gorzów Wlkp.

These first theses in biomechanics were defended outside the home unit of the authors, who did not have proper entitlements: A. Kabsch (1961) and E. Gniewkowski (1967) at the Medical Faculty of the University of Medical Sciences in Poznań, whereas S. Toboła (1963) at the Physical Education Faculty of the USPS in Warsaw. The supervisor for these doctoral theses was J. Kołaczkowski, MD, Dr. hab.

A problem that was similar to that of the above-mentioned doctoral theses was addressed at the Department of Biomechanics by three MA students of A. Kabsch. KURKIEWICZ [11] characterized the relationship between the strength of the plantar flexors and the angular position of the knee and talocrural joints [12], ŚMIDOWICZ described the relations between torque of the elbow joint flexors and the angle of the shoulder and elbow joints [12], and DWORAK studied the relationship between the torque of the palm flexors and the angular position of the elbow and radiocarpal joints [13].

3. Biomechanics of rowing

3.1. Genesis

Drafting this article the author asked himself the following question: Why has rowing become a subject of a long-standing research and very intensive biomechanical studies of the employees at the Department of Biomechanics?

The inspiration to take up biomechanics of rowing had a multidimensional basis. It certainly arose due to such reasons as:

a) relatively great ease of studying biomechanics of the cyclic motion of rowing, especially on a stationary device such as the rowing ergometer, or later the indoor rowing pool,

b) personal interests and experience of the Department of Biomechanics' team of that time and their contact with Z. Okupniak, MA, university teacher and at the same time a rowing coach,

c) appointment of the Ministerial Project PR 105 entitled "The effectiveness of training and competition as well as regeneration in sports" and assigning the USPS in Poznań during the 1970's decade the role of a coordinator of extensive research on the Rowing National Team,

d) interest in cooperation of a broad research team consisting of representatives of such fields as: biochemistry, biomechanics, physiology, hygiene, psychology, rehabilitation, theory of training, which undertook the task of conducting periodic, extensive research in form of expert evaluations of the training effectiveness of the Rowing National Team,

e) inspiration with a publication by FIDELUS and WYGANOWSKA [14] in 1970 that resulted in formulating (by several members of the team) the criteria for the assessment of rowing effectiveness.

3.2. A study of several technically advanced original research projects related to biomechanical research carried out on rowing ergometers

3.2.1. Studies of neuromuscular coordination in the rowing cycle

The issue of muscle coordination in the rowing cycle was a great challenge for the small group of the Department's employees and the cooperating specialists. This issue was previously addressed, e.g., in the works of ISHIKO [15] and LAZAREVA [16].

It was possible to carry out this project owing to the fact that the Department of Biomechanics had in its possession a 3-channel electromyograph DISA ELECTRONIC type 14A30, equipped with a prototype self-designed multiplexer module which enabled recording electromyographic activity of a dozen or so muscle groups using a round-robin method, without stopping rowing. The authors faced a huge problem consisting in the lack of elastic shielded wires for making electrodes as well as the construction of the electrodes themselves and a method for attaching them to the body. The wires were purchased at the TONSIL

plant with considerable difficulties related to the so called “hard currency contribution”, which was required from contractors. The dynamic tests produced also significant interference to the bioelectric signals, caused by continuous deformation of numerous and long electrode wires. After countless tests and consultations, using collodion to attach electrodes to the surface of the muscles, the testing methodology was finally mastered, including the thermal and perspiration effect of the skin on the electrodes during significant physical effort. At that time, in the leading, technologically advanced biomechanics centers of the world, electromyographic tests with the use of telemetric measurement paths were already conducted [15].

The rowing motion was forced by using a portable wooden rowing ergometer produced by H. HUNT, Liverpool, borrowed from a rowing club. The ergometer was equipped with contact sensors that defined the extreme positions of the sliding seat, to identify the duration of the rowing cycle and its phases (recovery and stroke) as well as an electrogoniometer, to determine the angular path of the oar during the cycle and its phases. The resistance of the oars during the stroke was produced mechanically. It was selected by way of expertise, on the basis of training experience, at the level of 110 Nm. An average pace of 28 cycles per minute was used during the tests.

The analysis included bioelectric activity of 18 muscles tested on the right-hand side of the body, representing the torso, the upper and the lower limb: *m. tibialis anterior*, *m. gastrocnemius*, *m. soleus*, *m. rectus femoris*, *m. semitendinosus*, *m. biceps femoris*, *m. gluteus maximus*, *m. rectus abdominis*, *m. errector trunci thoracalis*, *m. errector trunci lumbalis*, *m. latis-simus dorsi*, *m. trapezius p. superior and interior*, *m. deltoideus*, *m. biceps brachii*, *m. triceps brachii*, *mm. flexores carpi*, *mm. extensores carpi*.

The results presented in figure 4 apply to a 1st sports class rower [18]. They refer to the rowing cycle, increased by the recovery phase of the next cycle. The chart was created with the use of graphical methods of Eberhart, proposed for the analysis of gait [19]. The results analyzed were interpreted kinesiotically, describing the activity of selected muscles during 10 rowing cycles. The problem of optimizing muscle coordination was observed, which depended on the training of the rower [20].

The results of the electromyographic tests conducted on a dozen or so rowers were presented at two prestigious international conferences: 2nd Seminar on Biomechanics, Eindhoven [20] and Sympozjum Teorii Techniki Sportowej (Sports Technique Theory Symposium), Warsaw [18].

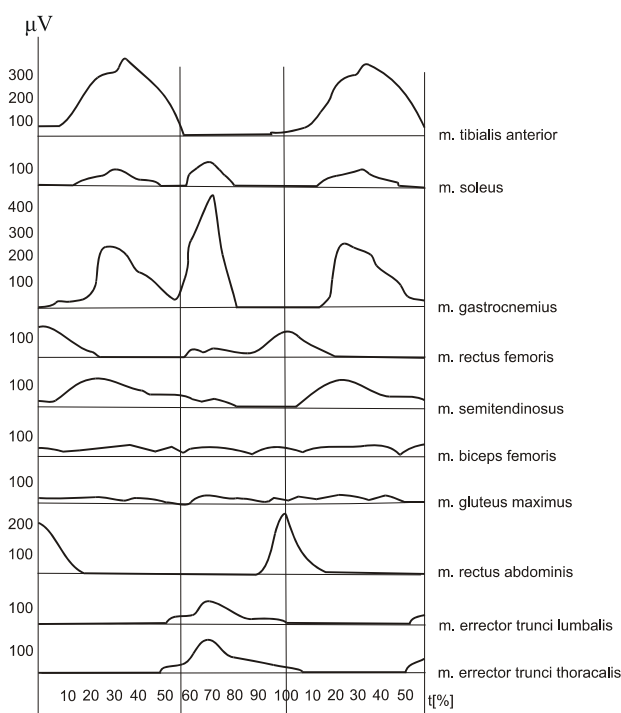

Fig. 4. Illustration of the testing method and sample results of electromyographic tests

The following persons took part in the technical works and the research related to this project: A. Kaminski, ME, an expert in biomedical engineering, and A. Lisiecki, an MA student at the Department.

3.2.2. The conception and realization of the research on universal Rowing Ergometer UEW-1; synthetic view

The UEW-1 Rowing Ergometer was designed according to the concept of A. Kabsch, MD, Dr. hab.

(consultant Z. Okupniak, MA) and constructed during the period of 1970–1972 at the Institute of Technical Machines of the Poznań University of Technology. The design team included of: A. Tułodziecki, ME, and J. Hańczarski, ME. Prior to the construction it was ensured that the employees of the Department of Biomechanics should have access to a professional (prototype) stationary measurement station that would reflect the motion pattern of a rower. This device was to make it possible to create a broad research program, addressing also the practical issues of the rowing training (expert opinions on the training).

A prototype two-seated device UEW-1 (equivalent of a double scull) is illustrated in figures 5 and 6.

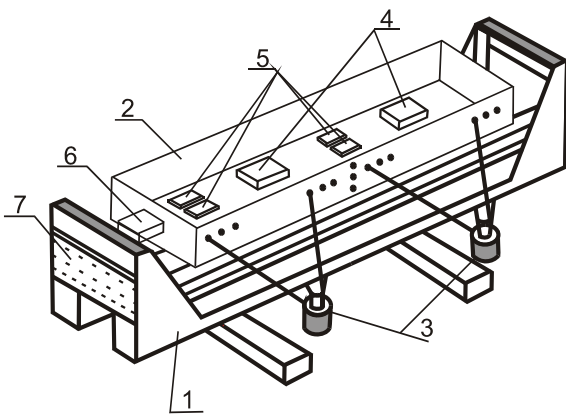

Fig. 5. Schematic diagram of a Universal Rowing Ergometer UEW-1. Labels described in the text

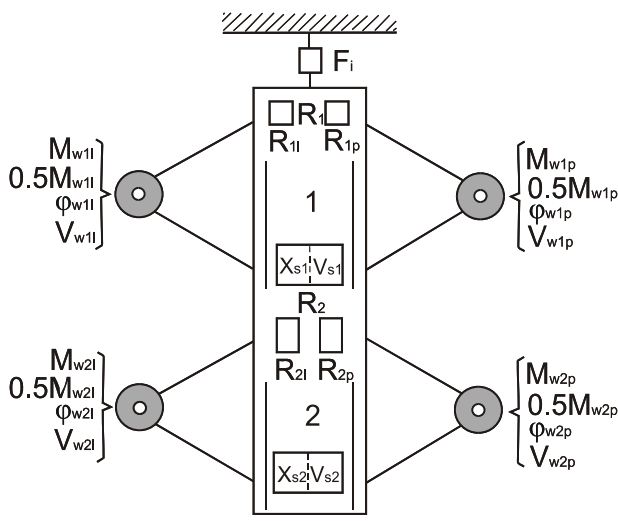

Fig. 6. Universal Rowing Ergometer, movable part module: measurement transducers placement – top view
Legend: F – force of inertia, M – torques,
 $0.5 M$ – independent transducers recording total values of torques,
 R – forces acting on the footrests, ϕ – oar motion (angular paths),
 X and V – displacement and velocity of the sliding seats, respectively

The station comprised the following elements:

1. Frame – being an equivalent of external environment (1), i.e. water, in the form of a fixed base, to which other elements were attached, including a sensor (induction transducer) for the measurement of the forces of inertia (6) – forces transferred from the mobile part (p. 2) to the frame of the ergometer.

2. A mobile part – with one level of freedom, being an equivalent of the boat (2), positioned on the frame over rolling bearings, which included:

2.1. A set of four weights – rowing resistance simulators, consisting of a system of drums mounted on equivalents of adjustable outriggers (3), equipped with motorcycle shoe brakes with a clutch system that produced resistance during the recovery phase. Torsional moment (of resistance during the driving phase of the oar) was measured with the use of strain gauge dynamometers. The weight set included also electrogoniometric transducers, which allowed the angular motion of the oars to be measured.

2.2. Accessories consisting of sliding seats (with original tracks) and foot rests (4 and 5), equipped with transducers recording linear displacement and velocity of the sliding seat as well as the forces produced at individual foot rests during rowing.

2.3. A switchboard (7) containing a set of sockets for connecting sensors with the measurement path, consisting of a strain gauge amplifier TT-6B and an analogue recorder in the form of an N-117 oscillograph.

A single measurement post was equipped with 13 measurement transducers, which were used with short oars (symmetric rowing) and 9 used with long oars.

The values of the following parameters were measured for each post:

- rowing cycle duration and duration of particular phases: recovery and stroke,
- path and velocity of the seat's motion,
- displacement and angular velocity of the left and the right oar,
- reaction forces on the left and the right foot rest as well as their total,
- torques of driving forces produced at the left and the right oar,
- force of inertia.

The adjustment of rowing resistance produced by weights-simulators was carried out before each testing series and consisted in providing (with the handwheels that controlled the pressure of the brake shoes) such values of resistance that were symmetrical for both weights – the left and the right one. The established resistance values were calibrated with spring dynamometers, by applying calibrating procedures

illustrated in figure 7. The dynamometer was hooked in the place that corresponded to the center of the handle grip.

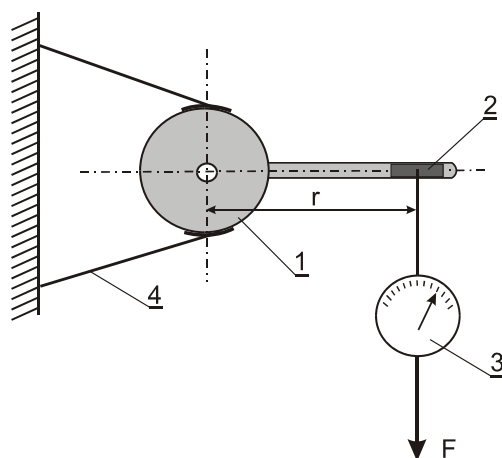

Fig. 7. Calibrating weights-resistance simulators, top view.
Legend: 1 – weights-simulator, 2 – oar handle, 3 – dynamometer,
4 – outrigger, r – arm of the force F

The design of the UEW-1 has been described in detail in the works of KABSCH [21] and KABSCH et al. [22], [23].

The UEW-1 station was not only used for theoretical investigation but also for a multiphase empirical research, mainly in 1973. The results of the empirical studies were described in detail in two collective works of DWORAK et al. [24], [25] as well as KABSCH et al. [26].

Among the more important and original achievements of the group of specialists in biomechanics, who conducted research at that time, were: creating two groups of original assessment criteria of rowing effectiveness, used to assess motion technique elements and energy of effort, as well as creating a classification system of the rowers tested – on the basis of assumed criteria. Prepared in this way, the results were handed over to the coaches and the research project coordinator.

In relation to the kinematic structure of motion (the technique), 5 criteria of rowing effectiveness were proposed, whereas in relation to the dynamic structure, 4 criteria were proposed. These criteria were further developed and expanded, among others, in the works of LISIECKI [27], [28] as well as LAMBUI and LISIECKI [29].

UEW-1 was not used in subsequent periodic tests of the National Rowing Team due to the reservations formulated by coaches and rowers. They mainly consisted of critical comments concerning the usefulness of tests carried out at a stationary measurement sta-

tion, in particular the method of producing resistance (load) in the stroke phase, while the college owned a classical – modern for the time – rowing pool. Furthermore, during intensive operation the station turned out to break down quite frequently, particularly the resistance production system.

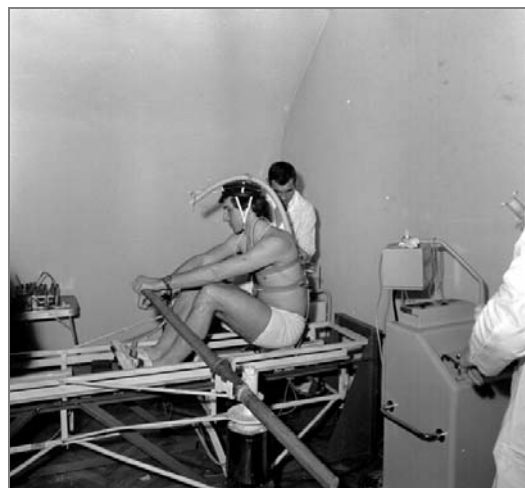

Fig. 8. Universal Rowing Ergometer UEW-1 used for biomechanical and physiological tests of the rowers

After a series of tests carried out in the first half of 1973 with the UEW-1 ergometer, a decision was made to end this program and create a new and original one. It would make use of the already owned infrastructure: a rowing pool and a complete set of equipment, access to the Institute of Research and Teaching Materials as well as the laboratory of the Department of Biomechanics, where the original ideas of the Research Team could be realized. At that time, the Team's members were: A. Kabsch, A. Lisiecki, L.B. Dworak, W. Lambui, J. Cabański., H. Parysek. During this period, the concept behind the doctoral thesis of A. Lisiecki was being created.

3.2.3. The study of muscle strength generated by rowers on the rowing ergometer

The research project related to the assessment of the muscle strength of the rowers taking part in the Central Training Program developed in a natural way. It arose mainly due to practical reasons: lower spine region overloads in rowers resulting from the specificity of the rowing motion, training in difficult environmental conditions, and intensive strength training and strength-endurance training within the annual training cycle. This phase of periodic tests (repeated 5 times during the period of 1970–1971) was realized mainly with the use of the rowing machine being at our disposal [30]. A very simple measurement station was designed, as illustrated in figure 9.

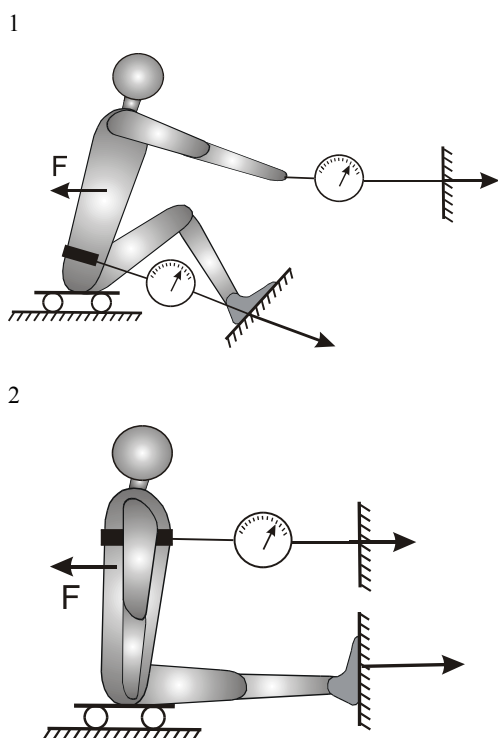

Fig. 9. Measurement station for testing “usable strength” of rowers.

1. Measurement position for testing the strength of muscles that control the motion of the oar and the sliding seat during the stroke phase.
2. Measurement position for testing the strength of the muscles of the back

The measurements were conducted in static conditions, in a closed biokinematic chain, in two positions. The first one, corresponding to the “catch” position, consisted in reproducing the arrangement of the rower’s body in the position of maximum recovery. Measurements were carried out along two measure-

ment paths (figure 9) with the use of spring dynamometers (DS-2k and DS-3k with the ranges of 2000 and 3000 N, respectively, produced by Spółdzielnia Mechaników (Mechanics Cooperative) in Poznań). They recorded forces generated by muscles controlling the motion of the oar handles and the pushing of the lower limbs away from the foot rests.

The second position corresponded to the final phase of the stroke, with extended lower limbs, perpendicular torso position and upper limbs lowered at ease. Force of the back muscles was measured, transferred along a perpendicular measurement path through a belt attached at the height of the shoulder blades and a connector to the dynamometer.

The results of the tests carried out during particular training periods were handed over to the coaches of the Team.

Several MA theses were completed as part of this project (including the ones of W. Erdmann and J. Leśny). They were supervised by Prof. A. Kabsch, MD, Dr. hab. Looking back at the measurement station and the protocol used for these tests years later, we assess them critically.

4. Summary

This paper reconstructs the early phase of research conducted at the Department of Biomechanics of the University School of Physical Education in Poznań, starting from the works related to the doctoral theses of A. Kabsch, S. Toboła and E. Gniewkowski and the habilitation thesis of A. Kabsch.

The author concentrated, according to the title of the paper, on the biomechanics of rowing, whose issues were studied in several research projects conducted by the employees of the Department of Biomechanics and later of the Department of Clinical Biomechanics. It was the leading research subject in the decade of the 1970’s, although it originated a little earlier.

The studies of the rowers on the Universal Rowing Ergometer UEW-1, conducted in cooperation with a team of physiologists, biochemists, psychologists and training theorists were for the employees of the Department of Biomechanics the first ones that had the character of applicable expert opinions on the training of the rowers (figure 8).

As already mentioned in chapter 3.2.3, experience gained in the course of this series of studies resulted in changing the concept of further phases of research conducted on the rowers who took part in the Central

Training Program, and creating a new project, which was reconstructed in the work of DWORAK [30].

Acknowledgement

This research project was financed from a fund for the statutory activity of the Department of Biomechanics. The author would like to thank A. Lisiecki, Ph.D., for granting access to the data included in his works as well as K. Kmiecik, ME, and J. Mączyński, MA, for their help in the preparation of illustrations and technical editorial work. I would also like to thank T. Wojtkowiak, Ph.D., for his help in completing the bibliography.

References

- [1] KABSCH A., DWORAK L.B., *Department of Biomechanics on the 60th anniversary of physical education*, Monograph 177, USPS in Poznań, 1979.
- [2] KOŁACZKOWSKI Z., MARECKI B., *Department of Functional Anatomy on the 60th anniversary of physical education*, Monograph 167, USPS in Poznań, 1979.
- [3] ERDMANN W.S., *Feliks Kamiński – a pioneer in biomechanics at the Higher School of Physical Education in Poznań*, Physical Education and Sport, 2004, 48, 295–297.
- [4] ERDMANN W.S., *Professor Aleksander Kabsch – an orthopaedic surgeon and a specialist in biomechanics*, Biology of Sport, 1998, 15 (Suppl. 8), 17–20.
- [5] KABSCH A., *Biomechanical analysis of some skiing elements in persons after amputations*, Doctoral Thesis, University of Medical Sciences in Poznań, typescript, 1961.
- [6] KABSCH A., *Biomechanical assessment of gait with the use of a prosthesis in persons after amputations above the knee joint, rehabilitated during ski camps*, Monograph 14, USPS in Poznań, 1966.
- [7] KULIG K., ANDREWS J.G., HAY J.G., *Human strength curves*, Exercise and Sport Sciences Reviews, 1984, 12, 417–466.
- [8] TOBOŁA S., *The influence of the hip joint and knee joint angles on the extending force of the knee joint*, Scientific Yearbooks of the USPS in Poznań, B. 17, 1969, 119–141.
- [9] GNIEWKOWSKI E., KUBIAK J., TOBOŁA S., *The adaptation of the Toboła device for strain gauge measurements*, Scientific Yearbooks of the USPS in Poznań, 1967, 14, 107–114.
- [10] GNIEWKOWSKI E., *The relationship between the knee joint flexor power and the position of the large joints of the lower limb*, Scientific Yearbooks of the USPS in Poznań, 1968, 15, 93–116.
- [11] KURKIEWICZ G., *The relationship between the strength of the plantar flexors and the angular position of the knee and talocrural joints*, Master's Thesis, USPS in Poznań, typescript, 1960.
- [12] ŚMIDOWICZ I., *The relationship between the torques of the forearm flexors and the angular position of the shoulder joint and the elbow joint*, Master's Thesis, USPS in Poznań, typescript, 1964.
- [13] DWORAK L.B., *The relationship between the force of the wrist flexors and the angular position of the elbow joint and the radiocarpal joint*, Master's Thesis, USPS in Poznań, typescript, 1966.
- [14] FIDELUS K., WYGANOWSKA A., *The distribution of horizontal components of forces and velocity and the assessment of rowing effectiveness in a single scull*, [in:] Sympozjum Teorii Techniki Sportowej (Sports Technique Theory Symposium), Warsaw, Sports and Tourism, 1970, 61–71.
- [15] ISHIKO T., *Application of telemetry to sports activities*, [in:] J. Wartenweiler, E. Jokl, Ky.M. Hebbelinc et al., Proceedings of the First Seminar on Biomechanics, BIOMECHANICS I, Medicine and Sport, 1968, 2, 148–146.
- [16] LAZAREVA A.M., *Analiz grebli po biotokom myshc i rabochemu efektu*, TiPFK, 1966, 7, 32–34.
- [17] LAZAREVA A.M., *Analysis of electrical activity of muscles during the rowing cycle*, Wioślarstwo (Rowing) B.1., Biblioteka Trenera Specjalisty (Training Specialist Library), Polish Olympic Committee, 1969, 24–37.
- [18] KABSCH A., DWORAK L.B., TOBOŁA S., SZMYT J., *From electromyographic studies of movement coordination in rowers*, Sympozjum Teorii Techniki Sportowej (Sports Technique Theory Symposium), Sports and Tourism, 1970, 224–229.
- [19] EBERHART H.D., INMAN V.T., BRESLER B., *The principal elements in human locomotion*, [in:] P.E. Klopsteg & P.D. Wilson (eds.), *Human limbs and their substitutes*, McGraw-Hill Book Company, Inc., 1954, 437–471.
- [20] KABSCH A., DWORAK L.B., TOBOŁA S., SZMYT J., *The Problem of Muscle Coordination in a Rowing Cycle in Electromyography*, 2nd Seminar Biomechanics, Eindhoven, 1969, 32–36.
- [21] KABSCH A., *Universal rowing ergometer (UEW-1) – measurement station for the measurement of rowing motion parameters*, Monograph 50, Research Results, Wioślarstwo (Rowing) II, USPS in Poznań, 1974, 57–69.
- [22] KABSCH A., DWORAK L.B., LISIECKI A., LAMBUI W., LEWANDOWICZ P., *Report from biomechanical studies of the rowing motion structure carried out on the Universal Rowing Ergometer UEW-1*, Research Results, Wioślarstwo (Rowing) II, USPS in Poznań, Monograph 50, 1974, 85–98.
- [23] KABSCH A., LISIECKI A., LAMBUI W., *Ergometric analysis of rowing on the universal rowing ergometer UEW-1*, Research Results, Wioślarstwo (Rowing) II, USPS in Poznań, Monograph 50, 1974, 99–110.
- [24] DWORAK L.B., KABSCH A., LAMBUI W., LISIECKI A., *Description of selected kinematic parameters in athletes taking part in the Central Training Program*, Research Results, Wioślarstwo (Rowing) III, Assessment of the rowing training in the 1973 season, USPS in Poznań, Monograph 61, 11–28.
- [25] DWORAK L.B., KABSCH A., LAMBUI W., LISIECKI A., *Description of selected dynamic parameters in athletes taking part in the Central Training Program*, Research Results, Wioślarstwo (Rowing) III, Assessment of the rowing training in the 1973 season, USPS in Poznań, Monograph 61, 29–36.
- [26] KABSCH A., DWORAK L.B., LAMBUI W., LISIECKI A., *Characteristics of kinematic and dynamic parameters of rowing movement in rowing pool and rowing ergometer*, Scientific Yearbooks of the USPS in Poznań, B. 26, 1977, 65–73.
- [27] LISIECKI A., DWORAK L.B., *Research trends in the biomechanics of rowing*, USPS in Poznań, Monograph 86, 1974, 379–392.
- [28] LISIECKI A., *Optimal model of rowing technique in the rowing pool*, Doctoral Thesis, USPS in Poznań, typescript, 1979, 109 p.
- [29] LAMBUI W., LISIECKI A., *The attempt to formulate biomechanical criteria for the assessment of the rowing technique in a pool*, Scientific Symposium “Sports Training Control

- Methods”, Scientific Bulletin of the USPS in Wrocław, B.23, 1977, 127–142.
- [30] KABSCH A., LISIECKI A., DWORAK L.B., *The development of muscle power in rowers taking part in the Central Training Program*, Research Results, Wioślarstwo (Rowing) II, USPS in Poznań, Monograph 50, 1974, 111–121.
- [31] DWORAK L.B., *Sports Biomechanics in the research of the Department of Biomechanics of the University School of Physical Education in Poznań*, Part II – *Rowing Biomechanics: tests in the rowing pool and under real conditions, reconstruction and synthesis*, Acta of Bioengineering and Biomechanics (to be published).